

WHOLE HOUSE

WF150K Whole House Central Water Filter

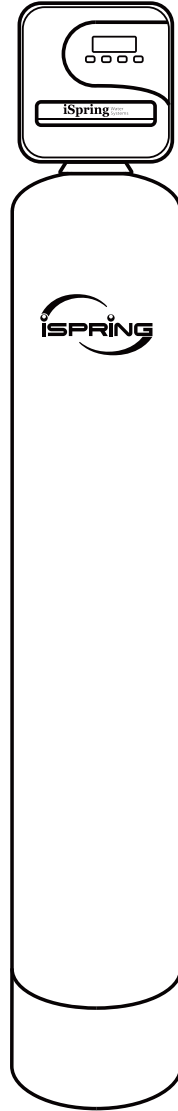

Model: WF150K

Installation Instructions & User Manual

Ver. 01/2023



iSpring Water Systems

Any questions?
Scan the QR code
for support.



Copyright ©2005-2023 ISPRING WATER SYSTEMS, LLC. All rights reserved.



We stand behind our products

Since 2005, iSpring has been dedicated to providing high-quality drinking water to families across the United States. We provide various residential faucets and water filtration systems that purify your water in everyday life and deliver pure, healthy, and tasty water to you and your family.

At iSpring, we strive to develop products to the highest of standards and aim to make excellent drinking water accessible for all households. With affordable pricing, reliable quality, prompt delivery, and top-notch customer service, we hope to assist in bringing you great water for years to come.

Prior to Installation

Read this instruction manual carefully prior to installation.

Keep this manual readily available for future reference.

Table of Contents

User Information & Guidelines	3
Dimensions	4
Material Details	5
Product Operation & Specifications	6
General Product Information	7
Notice	7
Installation Precautions	8
Installation Instructions	8
Operation Tips	11
Programming the Central Water Filtration System	11
Maintenance	13
Emergency Response	14
Troubleshooting	14
<u>Warranty</u>	
iSpring Standard Limited Warranty (End-Users Only)	
Warranty Registration Form	

User Information & Guidelines

The user must adhere to the specifications described in this Product Installation and Operation Manual (hereinafter referred to as the "instruction manual"). iSpring is not responsible for damage, loss, or injury resulting from neglect, improper maintenance, or unauthorized unit modification.

- The unit should be placed only on flat surfaces. Do not mount it on a wall.
- This product is designed for residential use. Contact iSpring customer service to inquire about using it in non-residential settings.
- The operating temperature range is 40°F - 100°F. If the water temperature or ambient temperature falls below 40°F, immediately shut off the inline water supply, turn off the inline water adapter, and drain the remaining water from the system. Failure of the water supply line or water purifier may result in malfunction, damage, and possible injury to the enclosure or water supply line.
- In case of malfunction due to damage or failure of the power supply system, unplug the system immediately and contact iSpring customer service.
- If leaking occurs, shut off the inline water supply by rotating the bypass valve to the bypass position. Then unplug the system and contact iSpring customer service.
- Use only authorized iSpring parts. Using unauthorized or aftermarket components will void the product warranty.
- This product has built-in systems to prevent internal leaks and minimize the risk of water damage. However, it is recommended that users check external fittings and connections regularly to ensure all components are secure.
- Unauthorized modification and disassembly are strictly prohibited and will void the warranty.
- Never touch the power cord connector when your hands are wet, as this may result in electric shock.
- Product installation and use must strictly comply with the requirements of this manual. Do not perform any operation on the product without reading and understanding the contents of this manual.
- Activation of this product indicates that the owner has carefully read, understood, and accepted the contents of this manual, including the safety notices and instructions.

Dimensions

TOP VIEW

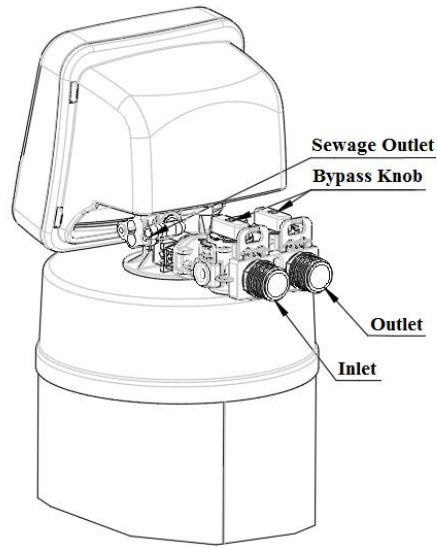

SIDEVIEW

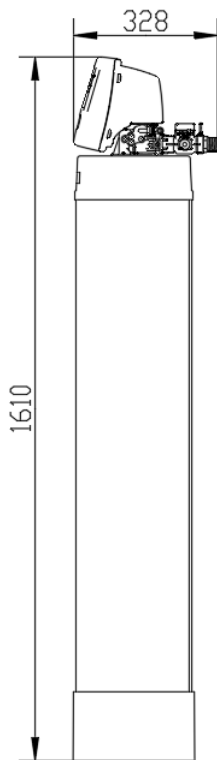

FRONTVIEW

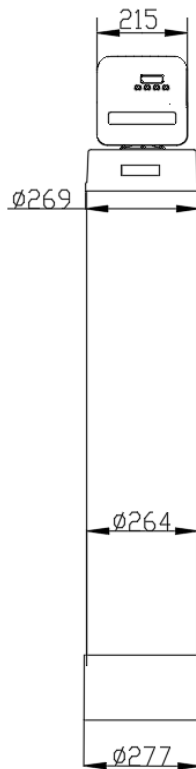

- Note:all dimensions are in millimeters unless otherwise specified.

Material Details

1. Inspect Shipment:

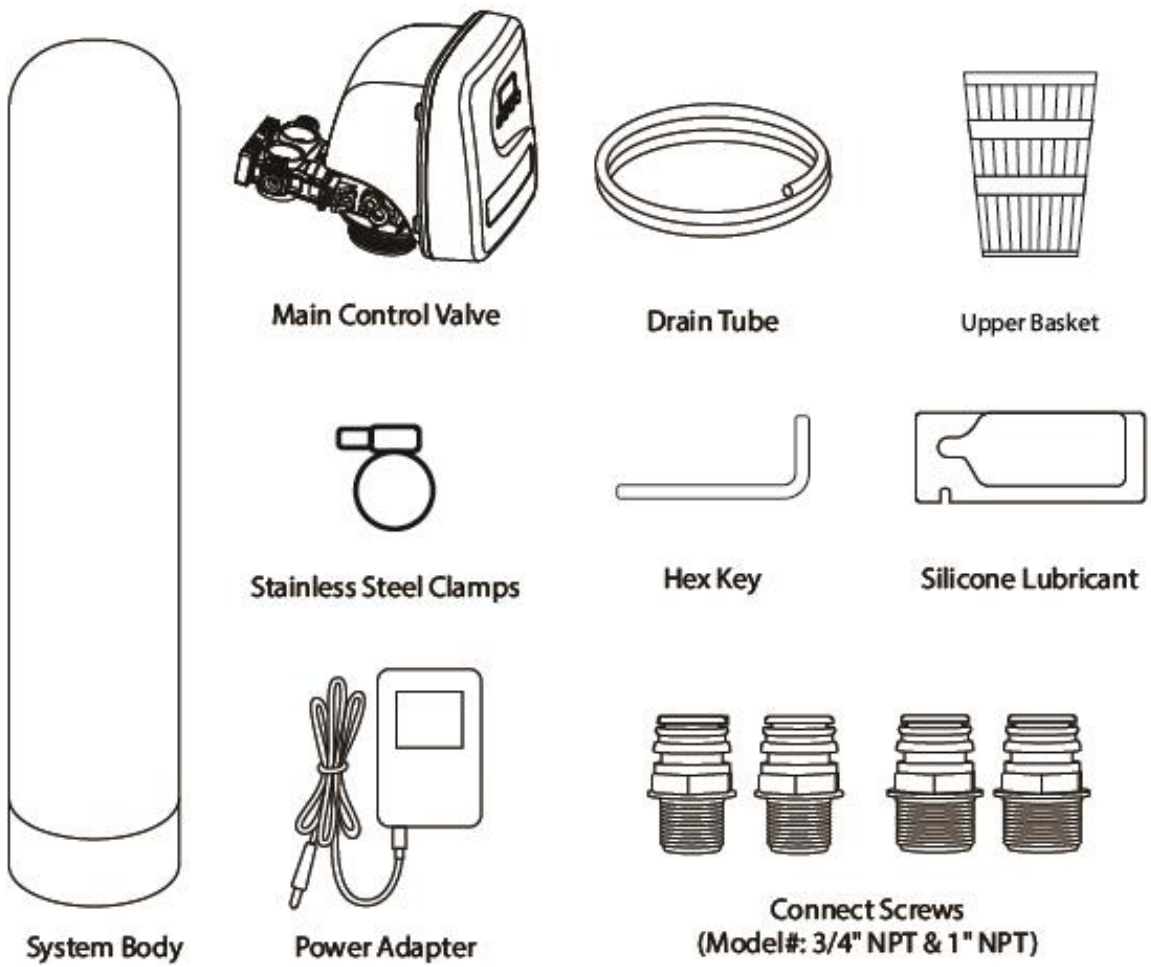

2. Bypass Assembly

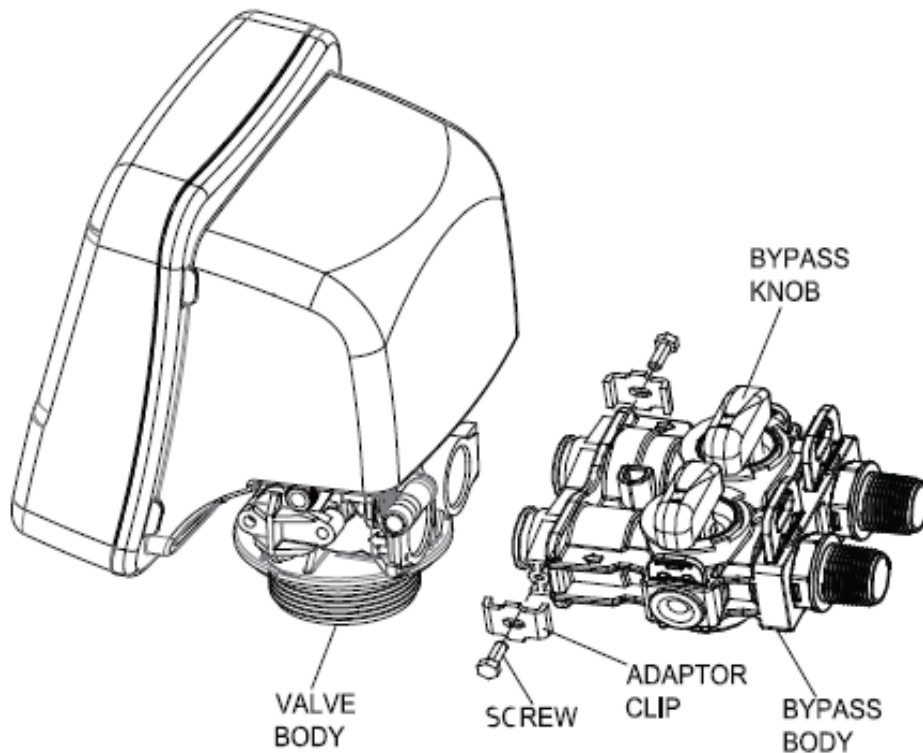

Product Operation & Specifications

Though testing was performed under standard laboratory conditions, the actual performance of the system may vary based on local water conditions and quality.

SPECIFICATIONS	
	Model WF150K
Hydrostatic Test Pressure	350 psi (24.15 bar)
Working Pressure Limits (minimum/maximum)	35~100 psi (241 kPa~689 kPa)
Water Temperature Limits (minimum/maximum)	40~100 °F (4~38 °C)
Required Riser Pipe Diameter	1.050 inch (26.7mm)
Electrical Adapter	Input: AC 120 V, 60 Hz Output: AC 12 V, 650 mA
Pressure Tank Thread	2 1/2" NPSM
Inlet/Outlet Connector	3/4" NPT / 1" NPT
Rated Service Flow	4 GPM
Peak Flow Rate	26 GPM

- This system is designed to be used on a cold supply ONLY and kept away from freezing environments.
- All inlet and outlet pipes are recommended to use water pipes and fittings that meet the appropriate standards of domestic drinking water. The connection of water pipes and circuits should comply with national or industry standards, and the pipe connections should comply with relevant federal installation regulations.
- If the water inlet pressure is higher than 100 psi, a pressure-reducing valve must be installed at the water inlet pipe of the water purifier. If the water inlet pressure is lower than 35 psi, a booster pump must be installed at the water inlet pipe of the water purifier to ensure the working pressure meets technical requirements.
- Heat preservation measures should be executed if the inlet water temperature is higher or lower than the requirement.

△Note

- Failure to operate the product per this manual may result in product damage, water leakage, seepage, injury, or other losses.

For questions or concerns, call **1-678-261-7611**, email **Support@123filter.com**, or visit **www.ispringfilter.com/support**.

General Product Information

The central whole house water filtration system utilizes high-quality KDF55, and coconut shell activated carbon to purify municipal tap water, effectively reducing odor, residual chlorine, and organic content.

The automatic backflush system is designed to flush and wash the filter media and move pollutants to the drain. The whole house central water filtration series carries excellent effluent water quality and abundant water purification flow, making the facility's water safe for use. The resulting purified water meets users' drinking and bathing requirements, including families, enterprises, and institutions.

There are three main working stages for this system, as shown below:

- 1) **Service:** After the machine filters the municipal pipeline water, it can provide drinking water per specifications.
- 2) **Backwash:** Backwash can remove the impurities remaining in the upper layer of the filter material and the toxic and harmful substances adsorbed in the filter material, restore the performance of the filter material, extend the life of the filter material, and prevent filter media from re-entering the water and compromising the water quality.
- 3) **Purge/Rinse:** Rinse the filter material, drain the dirty water, and fill the machine with filtered, purified water, compact the filter material, and keep the filter material always operating in high quality to best prepare for the next water purification cycle.

The main functions of this system are listed below.

- Fully Automatic Control
- A built-in time controller, twenty-four-hour time control. Based on the set number of interval days or the amount of treated water, the filter material is cleaned at the set regeneration time (usually in the early morning before any use).
- The regeneration cycle can be set based on time or treated water volume.
- Users can arbitrarily set the start time of the regeneration process.

Notice

△Warning

- This system can only be used with 120V/60Hz unidirectional AC power.
- Do not place objects on top of the power cord, and set the unit in an area where the power cord will not be stepped on or tripped over.
- Electric shock hazard: Do not overload sockets or extension cords.
- If there is smoke, abnormal odor, or abnormal noise coming from the machine, immediately unplug the system's power to avoid fire or electric shock.
- Do not touch the plug with wet hands to prevent electric shock.

(1) Location

- This system is required to be installed indoors. The installation location should be well-ventilated and protected against wind and rain. Avoid direct sunlight and radiation from any heat sources. Water leakage protection is highly recommended to be installed together with the system. If it needs to be installed outdoors, heat preservation measures must be taken for the body and pipes, including frost-proof, sun-proof, and waterproofing measures and insulation.
- The system's power supply and plug must be installed in a wall position higher than 500 mm above the ground and equipped with proper grounding, leakage protection, and waterproof devices.
- The installation location should be level, and the ground-bearing capacity should be greater than 300 kg/m².
- Ensure that there is proper space around the system, and do not apply any external force to the system or its connecting pipes.
- Do not install this system near corrosive substances or gases, as this may cause the system to corrode.
- This system should be installed out of reach of children.

(2) Others

- This equipment should never be tilted or placed horizontally during transportation, installation, or use.
- This sewage pipe should remain open at all times.
- Do not place flammable items on or near the product.
- The installation and commissioning of all machines can be conducted by yourself or a professional technician.

Installation Precautions

- The sewer drainage must be unobstructed, and there must be an air gap between the drain tube and sewage to prevent the sewage from flowing back into the system due to negative pressure.
- Before connecting the water inlet pipe, please remove any remaining impurities and dust in the pipe and close the main water supply before connecting it.
- When connecting screw parts, seal rings are generally installed. Please be aware that excessive force may cause the threads to slip and the screw to crack.

Installation Instructions

(1) General Bypass

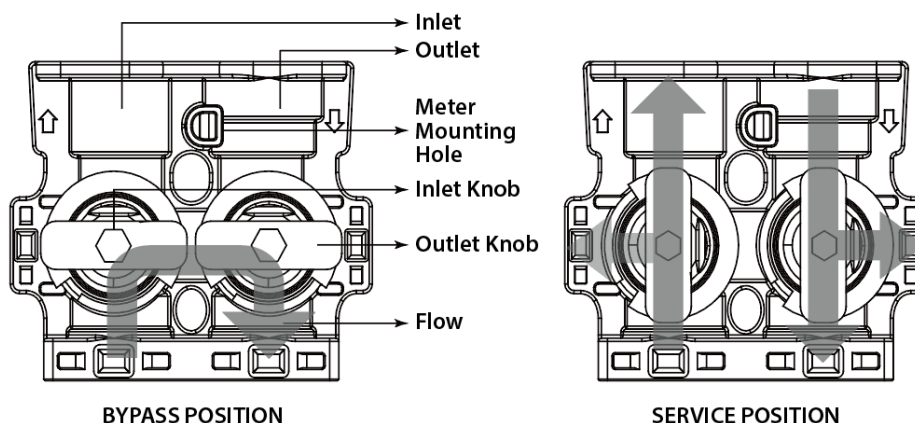

- a. Hold the knob or use a bypass tool to rotate the knobs. The water supply will be **bypassed** when the knobs are **horizontal**. The bypass valve is in **service** when knobs are oriented **vertically**. When the bypass valve is in service, users can take raw water and filter water samples for testing at the water-taking port on either side of the bypass.
- b. In case of equipment failure or other exceptional circumstances, the bypass can be adjusted to the bypass position, allowing users to use tap water temporarily. After the failure or problem is resolved, adjust the bypass to the vertical service position.

(2) Before Installation

- Verify the water source pressure; the acceptable range is 35 psi - 100 psi. If the pressure is higher or lower than this, it is recommended to install a pressure stabilizer.
- Do not remove the clips when the system is in operation; relieve the pressure before removing the clips.

(3) Equipment Installation

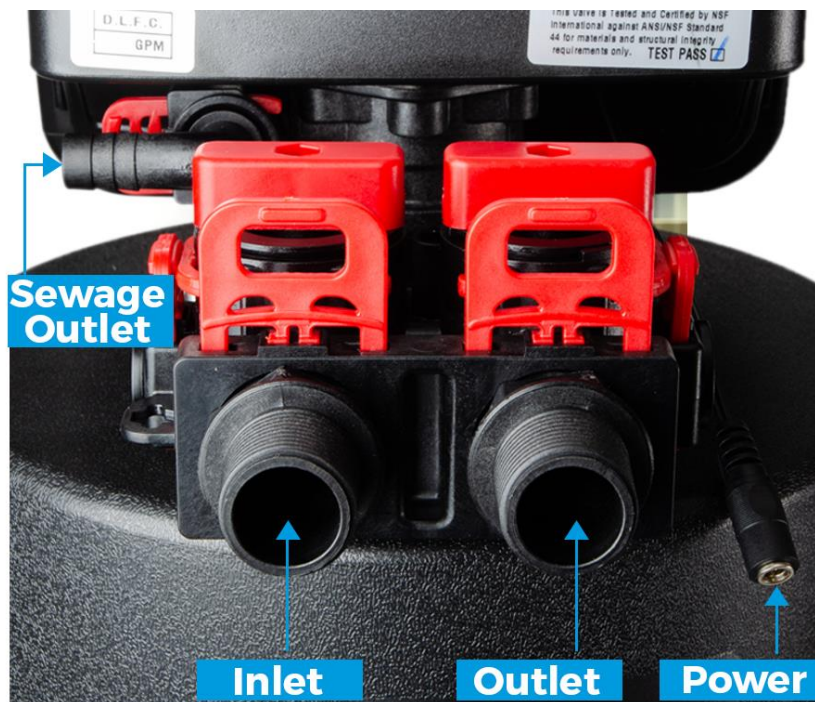

It is highly recommended that you watch the video *Installation & Startup | iSpring WF150K Whole House Water Filtration System | Step by Step* on YouTube.

- Step 1.** Confirm proper installation conditions, unpack the equipment and verify that all accessories are present. Prepare the installation tools and confirm that the installation site's water inlet and outlet pipes, power supplies, drain tube, and floor drain meet the appropriate requirements.
- Step 2.** **Lubricate** the inlet/outlet connect screw **o-ring** and tank **o-ring** seal. Install the **main control valve** on to the **system body**. Use only **food grade/included silicone lubricant**.
- Step 3.** **Close the main water supply** completely, then **open any faucets** in the room to remove the remaining water in the indoor water pipe.
- Step 4.** **Connect** the water **inlet** and **outlet** pipes of the system to the pipeline. Double check the direction of the water flow matches the sign on the system. Pay attention to the pipeline's height and placement angle when connected to prevent the connection pipes from bearing stress. While connecting pipes, keep the pipes as close to the wall as possible. The routing of the pipes should be straight, and the corners should be clear. The pipes should be fixed on the wall after installation.

Step 5. Connect the **drain** hose and **clamp** to the system tightly to ensure a secure connection. The other end of the drain hose goes to the **sewage** pipe.

There must be sufficient space (~10 cm) between the outlet of the drain hose and the sewage level to prevent sewage from flowing back to the product. The sewage pipe should be 30 cm higher than the ground, and the drain hose should be fixed on the sewage pipe.

Step 6. Plug in the **power adapter** and connect the other end of the socket to supply power to the system.

Step 7. Rotate the bypass valve knobs to the **bypass position**.

Step 8. Slowly **turn on the main water supply**.

Step 9. **Open a cold water tap** nearby and let the water run for a few minutes till the water runs clean or until the system is free of foreign material caused by plumbing work. Then **close the tap**.

Step 10. Then, slowly **open the water inlet knob** on the bypass valve (the valve should be opened at an angle of about 45°). **Start regeneration** and wait for the "**BACKWASH**" text on display to stop flashing and start to count down, then **unplug the power supply**, and keep the device in the backwash state.

✚ **All keys will lock after 3 minutes during the standby status. Press and hold the "MENU" key for 3 seconds to unlock.**

Step 10. a. To perform the **regeneration processes**, press and hold the "**SET/REGEN**" key for **3 seconds** in the unlocked state to enter manual regeneration mode.

Step 10. b. Press the "**SET/REGEN**" button again to select "**IMMEDIATE REGENERATION**".

Step 11. Let the water run until the air is purged from the unit (the exhaust sound disappears, and water steadily flows out of the drain hose), fully **open the water inlet knob** and let the water run until the water is clear, then **reconnect the power supply**. Press the "**SET/REGEN**" button to skip the rest of the regeneration process and until back to standby.

Step 12. Rotate the bypass valve knobs to the **service position** and observe whether there is water leakage or any other leakage at each connection. After ensuring safety, rotate the knobs to the **bypass position** and **soak** the filter material for **10 minutes**.

Step 13. Rotate the bypass valve knobs to the **service position**. Next, perform at least **two filter material washing processes**.

Step 13. a. To perform the **filter material washing processes**, press and hold the "↑"/"↓" keys for **3 seconds** in the unlocked state to enter the user menu settings.

Step 13. b. Press the "**SET/REGEN**" button to confirm the parameter setting and enter the next parameter setting option.

**BACKWASH
15 MINUTES**

**RINSE
10 MINUTES**

Step 13. c. Press the "↑"/"↓" keys to adjust the value.

Step 13. d. Press the "**SET/REGEN**" button again to confirm the parameter setting and until "**PROGRAMMING COMPLETE**".

Step 13. e. Press and hold the "**SET/REGEN**" button for 3 seconds to enter the manual regeneration mode.

Step 13. f. Press the "**SET/REGEN**" button again to select "**IMMEDIATE REGENERATION**".

✚ **Filter material washing process: backwash (5-10 minutes) and rinse (5 minutes).**

Step 14. **Open a cold water tap** nearby and let the water run for at least 5 minutes or until the water is clear. Then **close the tap**. Verify the water is completely clear before use.

Step 15. Check again for any water leakage in the pipeline and whether the fittings at the connection parts with the original pipeline cause loosening or water seepage from construction.

Step 16. Set up the system parameters of the equipment (see Programming the Central Water Filtration System for details, page 11-13).

✚ **Default regeneration process: backwash (15 minutes) and rinse (10 minutes).**

Step 17. Clean the installation site.

Operation Tips

- The product can be generally used after installation and commissioning have been completed. With an uninterrupted power supply, the user does not need to perform other operations on the machine.
- The automatic regeneration start time default is to start late at night. The water is not treated and should not be used during this time.
- During the use of the system, do not cut off the power to avoid errors in the clock on the system, which will affect the original regeneration start time and lead to the potential use of untreated water.
- When the water supply is shut down, the system should be in the bypass position. When the water supply is restored, the faucet in the home should be opened first. When the water supply is restored after the water supply is shut down, pollutants in the water pipe may enter the system and damage the machine, leading to filter failure. The contaminated water should be released, and the system should return to the service position after the water runs clear.
- DO NOT regenerate any other softeners/filters at the same time as this system since this will interfere with the regeneration process and cause damage.

Programming the Central Water Filtration System

1) Button Configuration

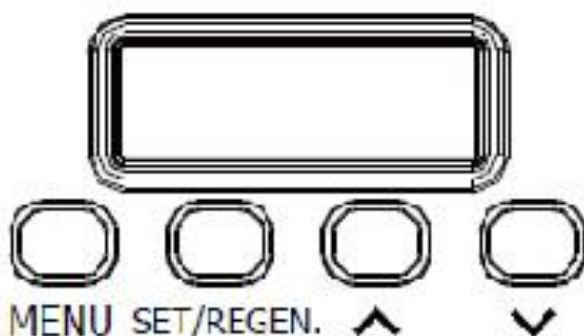

- a. "Menu"
This function is used to enter the basic setup information required during installation.
 - Press and hold the key for 3 seconds to unlock the device while in standby mode.
 - In the user menu setting, press this button to exit the menu immediately.
- b. "Set/Regen"
This function is used to initiate an immediate or delayed manual regeneration.
 - In the user menu setting, press this button once to confirm the parameter setting and switch to the next option.
- c. "UP" / "DOWN"
These buttons are used to increase or decrease the value of the settings while in programming mode.
 - When the display is in a menu option, these keys can be used to adjust the value or option.

2) Notes

- a. During the menu setting process, if there is no activity within 1 minute, the system will automatically return to the standby state.
- b. All keys will lock after 3 minutes during the standby status. Press and hold the "Menu" or "SETTINGS" key for 3 seconds to unlock.

3) Programming Levels

There are four levels of the valve program:

a. Settings

Press and hold "Menu" for 3 seconds to enter.

Use the "UP" and "DOWN" buttons to modify the value. Press the "Menu" button once to confirm and switch to the following parameter setting, the entire menu shown below. Press "Set/Regen" to immediately return to the standby state.

TIME OF DAY 12:01 PM
YEAR 2012
MONTH AUGUST
DAY 21
REGEN DAYS 3 DAYS
GALLONS OFF
REGEN. TIME 02:00 AM
LOAD DEFAULT NO
PROGRAMMING COMPLETE

TIME OF DAY, YEAR, MONTH, DAY:

Time of day is for the regular operation of the system and the scheduling of the regeneration time. The date is used in a diagnostic function to track the last time the system regenerated.

REGEN. DAYS:

The number of days between regenerations or backwashes to clean the filters. The user can set the number of days in the regeneration cycle according to the water situation.

GALLONS:

The default value is "2100 GAL". Adjust the GALLONS to set the capacity. This will cause the unit to regenerate either when the gallons remaining go zero or when the days between regeneration are zero. Whichever occurs first.

REGEN. TIME:

Determines the time of day to perform a scheduled regeneration. You can set the system's regeneration time according to your routine. It is recommended to set it in a period when water is not in use. The system defaults to 02:00 a.m.

LOAD DEFAULT:

If the selection is made, the processing time of each regeneration cycle will be reset to the default value set. The rinse time will return to the default value.

b. Factory Options

Press and hold "Menu" and "Set/Regen" at the same time for 3 seconds to enter.

Press "Set/Regen" to confirm and switch to the following parameter setting, the entire menu shown below. Use the "UP" and "DOWN" buttons to modify the value. Press the "Menu" or button to return to the standby state immediately.

LANGUAGE ENGLISH FRENCH
UNITS GALLONS METRIC
SMART CLEAN OFF
PROGRAMMING COMPLETE

SYSTEM LANGUAGE:

Choose the system language.

UNITS:

Choose the system unit of measurement: metric or gallons.

SMART CLEAN:

When set to ON, the system will perform a 10 (adjustable) minute backwash and rinse if there is no water flow detected after 7 (adjustable) days. The regeneration will occur at the scheduled REGEN TIME.

c. Advanced Options

Press and hold "UP" and "DOWN" at the same time for 3 seconds to enter.

Press "Set/Regen" to confirm and switch to the following parameter setting, the entire menu shown below. Use the "UP" and "DOWN" buttons to modify the value. Press the "Menu" button to return to the standby state immediately.

BACKWASH 15 MINUTES
RINSE 10 MINUTES
LOCK VALUE UNLOCK
PROGRAMMING COMPLETE

BA. WA. DURATION (BACKWASH DURATION) / RINSE DURATION:
Users can adjust these parameters at any time with the help of an application engineer based on the water environment.

LOCK VALUE:
This setting locks the value set on this previous page, and the end-user will not be able to modify it before this setting is changed to UNLOCK.

d. Regeneration Mode Options

Press "SELECT" button once to enter "DELAYED REGEN." function. Use the"↑" and "↓" button to change the mode. Press "SELECT" to confirm the setting.Press the "SETTING" button to immediately return to the standby state.

DELAYED REGEN. OFF

DELAYED REGENERATION
In this mode, the system will start a regeneration at the next regeneration time regardless of the remaining regeneration days or water consumption.

Press and hold the "SELECT" button for 3 seconds to enter the "REGENERATION" setting. Use the"↑" and "↓" button to switch the modes. Press "SELECT" to confirm the setting. Press the "SETTING" button to immediately return to the standby state.

REGENERATION IMMEDIATELY
REGENERATION VACATION MODE

IMMEDIATE REGENERATION
Under this mode, the system immediately starts a regeneration.

VACATION MODE
Choose vacation mode and input estimated holiday days; the valve will regenerate in a SMART CLEAN mode. The system will remain in vacation mode when no water is used during the input estimated holiday days; if there's water used, the vacation mode will be auto-off, and the system will return to the normal working mode.

Maintenance

- Regularly get your water tested to ensure the system is working properly.
- Media needs to be refilled only when the system reaches capacity or accidentally gets contaminated. The media replacement process needs to be conducted with a professional or under professional guidance. For related questions, contact the iSpring Customer service team.
- Systems installed outdoors without regular maintenance will fail sooner than those installed indoors. It is recommended that you check the product and maintain it regularly. Call us immediately if anything goes wrong.
- Do not operate this equipment if you have not read and truly understood this manual.

- If the equipment fails or experiences other exceptional circumstances, the inlet and outlet valves can be closed (the bypass valve is open), and the municipal water supply can be used directly. After removal, open the water inlet and outlet valves of the device.
- During regular use of the bypass, do not pull out the clamp. The pressure must be released before the clamp is removed.

Emergency Response

- If the equipment fails or experiences other exceptional circumstances, the inlet and outlet valves can be closed (bypass position), and the municipal water supply can be used directly. Reopen the system's water inlet and outlet valves once the emergency is fixed.
- If water consumption increases significantly (compared to normal usage) or the quality of raw water decreases, the number of regenerations should be increased accordingly.
- During the process of system regeneration, if the system experiences a power loss, more than one discharge may occur, resulting in the waste of water resources.
- In case of power failure, readjust the current time and regeneration start time according to the manual after the power supply is restored.
- When the water supply in a residential area is shut down, the main water main valve should be closed immediately. The municipal water supply may cause negative pressure on the household pipeline and damage the equipment.

If you have any questions or concerns during the installation, please contact us at support@123filter.com or visit our help page at 123filter.com/support

Troubleshooting

ISSUE	POSSIBLE CAUSE	POSSIBLE SOLUTION
<i>Unit fails to initiate a regeneration cycle</i>	No power supply	Check electrical service, fuse, etc.
	Power failure	Reset time.
<i>Low water pressure</i>	Iron or scale builds up in line feeding unit	Clean pipes or add WDS series or ED2000 before the system.
	Iron builds up inside the valve or tank	Increase regeneration frequency.
	Inlet of control plugged due to foreign material	Remove the piston and clean the control valve.
<i>Control valve without display</i>	Power failure, the power adapter is not plugged in	Check the power supply to ensure a regular or restored power supply.
	Power off while regeneration	Turn the bypass valve to the bypass position or close the control valve.
	Control valve failure	Contact us.

Poor water quality	The Control valve clock is inaccurate due to a power failure, causing the regeneration start time to be changed	Adjust the control valve's current time. For operating procedures, refer to the current time in the control valve manual.
	Poor source water quality	Add an additional regeneration process. Refer to the setting of the regeneration cycle in the control valve manual for the operating procedure.
	Filter failure	Contact us.
	Regenerate too often or too little	The regeneration cycle setting is not optimal. Adjust the regeneration cycle of the control valve and refer to the setting of the regeneration cycle in the control valve manual for the operating procedure.
	Incoming water quality does not meet national municipal tap water standards	Contact the relevant local water supply department or add the WSP and WGB series before the system.
	Water system pressure is too low or too high	Install pressure stabilization equipment.
	Control valve failure	Contact us.
Filter material performance reduce	The backwash flow rate is too large or too small	Verify the water pressure is 35 ~ 100 psi.
Regeneration start time is incorrect	The control valve is inaccurate due to power failure	Adjust the current time of the control valve.
	The regeneration start time is set incorrectly	Adjust regeneration start time. For operating procedures, refer to the current time in the control valve manual.

Need help with troubleshooting? If you have any questions or find there are missing parts or damage, please call **1-678-261-7611** or visit **www.ispringfilter.com**

When calling, please be prepared to provide the model of your product.

(The model of this product is "WF150K".)

iSpring Standard Limited Warranty (End-Users Only)

In order to be eligible for this warranty, the end-user must register at www.123filter.com.

For all water filtration systems, and upon registration by the end-user, iSpring Water Systems, LLC (iSpring) warrants for a one year from the date of purchase that the product is free of defects in materials and workmanship and that it will function for the duration of the warranty according to its specifications (the "Limited Warranty"). EXCEPT FOR THIS LIMITED WARRANTY, ISPRING EXPRESSLY DISCLAIMS ANY AND ALL REPRESENTATIONS AND WARRANTIES, WHETHER EXPRESS, IMPLIED, OR STATUTORY, INCLUDING ANY WARRANTIES OF TITLE, NON-INFRINGEMENT, MERCHANTABILITY OR FITNESS FOR A PARTICULAR PURPOSE. iSpring has no liability for any defect or deterioration which results from the improper installation, service, repair or use of the product. End-user's sole and exclusive remedy for any breach of the Limited Warranty shall be repair or replacement, at iSpring's option and expense. This warranty is only provided to end-users and only applies to products purchased directly from an authorized iSpring dealer or reseller.

However, we do not have the order information from websites other than 123Filter.com (Amazon, Home Depot, etc.), so please be sure to fill in that information upon registration of your system. If you have any questions or concerns about your product, please do not hesitate to call or email us, or put it in the notes/comments upon your warranty registration. Your satisfaction is our business!

If you are happy with our products and service, please show your support by writing a product review on Amazon, even just a single line. It takes you just a minute but means a lot to us. Thank you!

Warranty Registration Form

Name _____ Order# _____

Email _____ Phone _____

Address _____

City _____ State _____ Zip Code _____

Model #/ Serial Number

Purchased at (e.g. Amazon, Home Depot)

iSpring Water Systems, LLC
2480 Industrial Park Blvd, Cumming, GA 30041
678-261-7611

Plumber's information (Optional)

To best serve our customers, we'd like to recommend good plumbers throughout the USA. If you are happy with your installer, please provide their information so that we can pass it on as a courtesy.

Thank you!

Name of the plumbing company used to install your system:

Phone #: (_____) - _____ or email : _____
of the technician.



Like our products?
Please show your support by writing a product review on the marketplace where you make your purchase. Even just a quick statement means a lot to us.

Thank you!

iSpringFilter.com

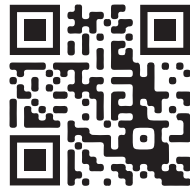

For questions, comments, or technical support, please contact us at:

✉ support@123filter.com

☎ +1 (678) 261-7611

💬 +1 (470) 560-0012

Monday-Friday 8:30 a.m. - 5:30 p.m. EST

Water's Good[®]
