

# WHOLE HOUSE

## iSpring WCS45KG Whole House Central Softener

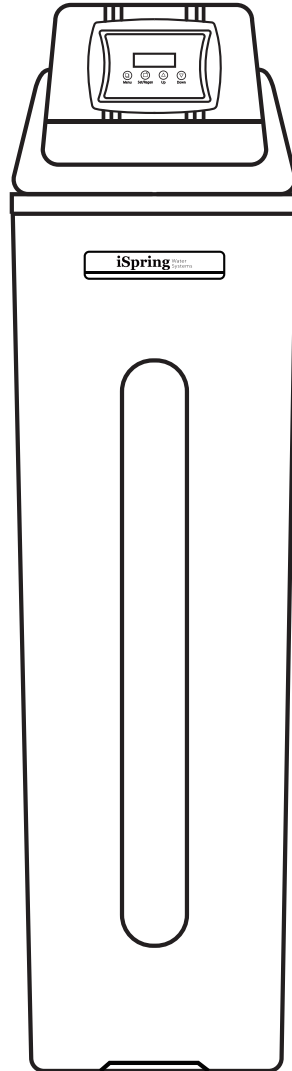

Model: WCS45KG

## Installation Instructions & User Manual

Ver. 10/2022



Copyright ©2005-2022 ISPRING WATER SYSTEMS, LLC. All rights reserved.





*We stand behind our products*

Since 2005, iSpring has been dedicated to providing high-quality drinking water to families across the United States. We provide various residential faucets and water filtration systems that purify your water in everyday life and deliver pure, healthy, and tasty water to you and your family.

At iSpring, we strive to develop products to the highest standards and aim to make excellent drinking water accessible for all households. With affordable pricing, reliable quality, prompt delivery, and top-notch customer service, we hope to assist in bringing you great water for years to come.

## **Prior to Installation**

**Read this instruction manual carefully prior to installation.**

**Keep this manual readily available for future reference.**

## **Table of Contents**

User Information & Guidelines .....	3
Dimensions .....	4
Product Operation & Specifications .....	5
Material Details .....	6
General Product Information .....	7
Notice .....	8
Installation Precautions .....	8
Installation Instructions .....	9
Operation Tips .....	12
Programming the Central Softener System .....	12
Emergency Response .....	16
Maintenance .....	16
Troubleshooting .....	17
<b><u>Warranty</u></b>	
iSpring Standard Limited Warranty (End-Users Only) .....	
Warranty Registration Form .....	

## User Information & Guidelines

The user must adhere to the specifications described in this Product Installation and Operation Manual (hereinafter referred to as the "instruction manual"). iSpring is not responsible for damage, loss, or injury resulting from neglect, improper maintenance, or unauthorized unit modification.

- The unit should be placed only on flat surfaces. Do not mount it on a wall.
- This product is designed for residential use. Contact iSpring customer service to inquire about using it in non-residential settings.
- The operating temperature range is 40°F - 100°F. If the water temperature or ambient temperature falls below 40°F, immediately shut off the inline water supply, turn off the inline water adapter, and drain the remaining water from the system. Failure of the water supply line or water purifier may result in malfunction, damage, and possible injury to the enclosure or water supply line.
- In case of malfunction due to damage or failure of the power supply system, unplug the system immediately and contact iSpring customer service.
- If leaking occurs, shut off the inline water supply by rotating the bypass valve to the bypass position. Then unplug the system and contact iSpring customer service.
- Use only authorized iSpring parts. Using unauthorized or aftermarket components will void the product warranty.
- This product has built-in systems to prevent internal leaks and minimize the risk of water damage. However, it is recommended that users check external fittings and connections regularly to ensure all components are secure.
- Unauthorized modification and disassembly are strictly prohibited and will void the warranty.
- Never touch the power cord connector when your hands are wet, as this may result in electric shock.
- Product installation and use must strictly comply with the requirements of this manual. Do not perform any operation on the product without reading and understanding the contents of this manual.
- Activation of this product indicates that the owner has carefully read, understood, and accepted the contents of this manual, including the safety notices and instructions.

## Dimensions

TOP VIEW

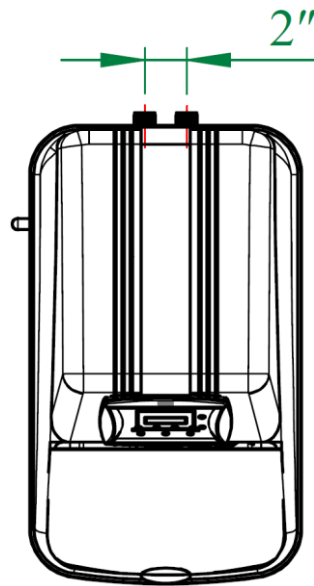

SIDE VIEW

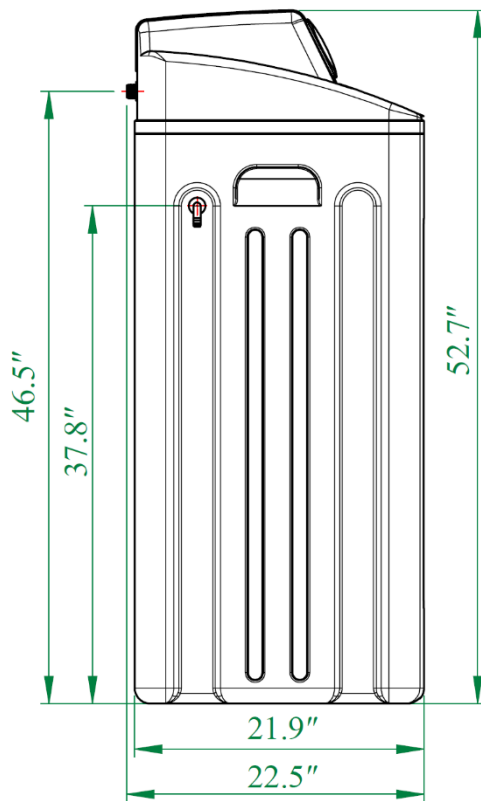

FRONT VIEW

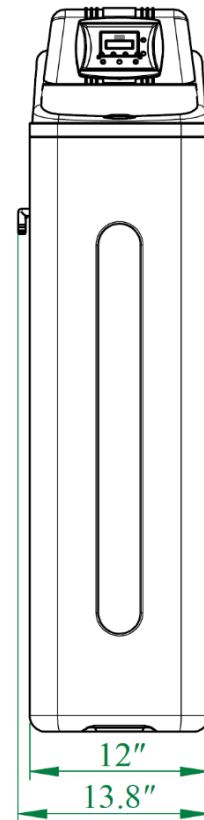

## Product Operation & Specifications

Though testing was performed under standard laboratory conditions, the system's performance may vary based on local water conditions and quality.

SPECIFICATIONS	
Working Pressure Limits (min./max.)	21~64 psi
Water Temperature Limits (min./max.)	40~100 °F (4~39 °C)
Required Riser Pipe Diameter	1.050 inch (26.7 mm)
Electrical Adapter	Input: AC 120 V, 60 Hz Output: AC 12 V, 650 mA
Pressure Tank Thread	2.5" NPSM
Inlet/Outlet Connector	1" NPT
Rated Service Flow Rate	8 GPM (30 L/min.)
Peak Flow Rate	26 GPM
Capacity	45000 grain

- This system is designed to be used on a cold supply ONLY and kept away from freezing environments.
- All inlet and outlet pipes are recommended to use water pipes and fittings that meet the appropriate standards of domestic drinking water. The connection of water pipes and circuits should comply with national or industry standards, and the pipe connections should comply with relevant federal installation regulations.
- If the water inlet pressure is higher than 64 psi, a pressure-reducing valve must be installed at the water inlet pipe of the water purifier. If the water inlet pressure is lower than 21 psi, a booster pump must be installed at the water inlet pipe of the water purifier to ensure the working pressure meets technical requirements.
- Heat preservation measures should be executed if the inlet water temperature is higher or lower than the requirement.

### △Note

- Failure to operate the product per this manual may result in product damage, water leakage, seepage, injury, or other losses.

For questions or concerns, call **1-678-261-7611**, email **Support@123filter.com**, or visit **www.ispringfilter.com/support**.

## Material Details

1. Inspect the packaging for the following components:



One machine and these accessories are included:

- ① power adapter (white box, 1 pcs.)
- ② sewage and overflow pipe (a translucent pipe, 1 pcs.)
- ③ stainless steel clamps (in the PE bag, 2 pcs.)
- ④ hex key (in the PE bag, 1 pcs.)
- ⑤ connect screws NPT1M (in the PE bag, 2 pcs.)
- ⑥ O-rings (in the PE bag, 2 pcs.)
- ⑦ grease (in the PE bag, 1 pack)

2. Bypass Assembly:

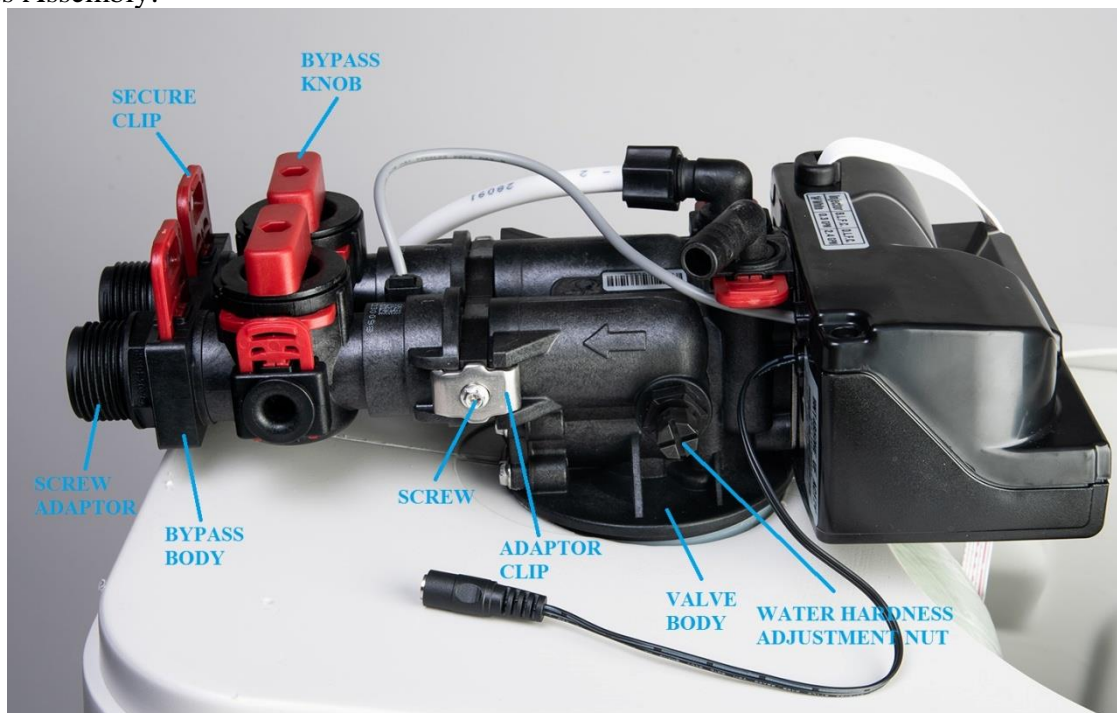



## General Product Information

iSpring's whole-house central softeners provide large water output, optimal water softening, and stable performance. They can also be fully automatic and intelligent in operation, regeneration, and dynamic salt dissolution. In addition, these softeners not only meet the needs of household bathing, laundry, cleaning, water heaters, etc., but they also provide softened water for businesses, institutions, hospitals, schools, and other enterprises.

This product uses cation-exchange resin to remove cations from the water, such as calcium and magnesium. There are three main working stages for this system, as shown below:

- 1) **Service:** After the source water flows through the water softener at an absolute pressure and flow rate, the  $\text{Na}^+$  in the ion exchange resin exchanges with  $\text{Ca}^{2+}$ ,  $\text{Mg}^{2+}$ , and other cations in the water to reduce the concentration of  $\text{Ca}^{2+}$  and  $\text{Mg}^{2+}$  ions, thereby softening the water quality.
- 2) **Backwash:** After the ion exchange resin is saturated, it must be backwashed before regeneration. The purpose here is to wash away the suspended, retained, agglomerated impurities on the resin surface and remove any broken resin. The other purpose is to loosen the compressed resin layer, which benefits ion exchange resin regeneration.
- 3) **Brine:** With a specific concentration and flow rate, the salt solution flows through the entire ion exchange resin layer to regenerate the saturated resin and restore the original softening exchange capacity.
- 4) **Rinse:** Removes any remaining brine between the resin and wash until the water is qualified; presses the resin layer tightly to achieve a high-quality softening effect.
- 5) **Refill:** Replenish the brine tank with water that dissolves the salt for regeneration to produce a saturated brine for the next regeneration.

The main functions of this system are listed below.

- Fully Automatic Control
- A built-in time controller, twenty-four-hour time control. Based on the set number of interval days or the amount of treated water, the filter material is cleaned at the set regeneration time (usually in the early morning before any use).
- The control system can calculate and design an economical and effective soft water treatment plan based on the water source and the treated water volume.
- The regeneration cycle can be set based on time or treated water volume.
- Users can arbitrarily set the start time of the regeneration process.
- Produce a saturated brine with a uniform concentration

The brine tank's water is replenished from bottom to top, and the brine settles from top to bottom by natural convection, evenly mixing the brine until it reaches a saturated state.

## Notice

### **△Warning**

- This system can only be used with 120V/60Hz unidirectional AC power.
- Do not place objects on top of the power cord, and set the unit in an area where the power cord will not be stepped on or tripped over.
- Electric shock hazard: Do not overload sockets or extension cords.
- If there is smoke, abnormal odor, or abnormal noise coming from the machine, immediately unplug the system's power to avoid fire or electric shock.
- Do not touch the plug with wet hands to prevent electric shock.

### **(1) Location**

- This system is required to be installed indoors. The installation location should be well-ventilated and protected against wind and rain. Avoid direct sunlight and radiation from any heat sources. Water leakage protection is highly recommended to be installed together with the system. If it needs to be installed outdoors, heat preservation measures must be taken for the body and pipes, including frost-proof, sun-proof, and waterproofing measures and insulation.
- The system's power supply and plug must be installed in a wall position higher than 500 mm above the ground and equipped with proper grounding, leakage protection, and waterproof devices.
- The installation location should be level, and the ground-bearing capacity should be greater than 300 kg/m<sup>2</sup>.
- Ensure that there is proper space around the system, and do not apply any external force to the system or its connecting pipes.
- Do not install this system near corrosive substances or gases, as this may cause the system to corrode.
- This system should be installed out of reach of children.

### **(2) Others**

- This equipment should never be tilted or placed horizontally during transportation, installation, or use.
- This sewage pipe should remain open at all times.
- Do not place flammable items on or near the product.
- The installation and commissioning of all machines can be conducted by yourself or a professional technician.

## Installation Precautions

- The overflow pipe and the sewage pipe must be connected to the sewer separately, and the two must not be combined and then transferred to the sewer. The sewer drainage must be unobstructed, and there must be an air gap between the sewage pipe and sewage to prevent the sewage from flowing back into the system due to negative pressure.
- Before connecting the water inlet pipe, please remove any remaining impurities and dust in the pipe and close the main water supply before connecting it.
- When connecting screw parts, seal rings are generally installed. Please be aware that excessive force may cause the threads to slip and the screw to crack.
- Connect the hose to the brine suction port on the control valve, connect the other end to the brine valve, tighten the nut, and ensure all connections are tight to prevent leakage.

# Installation Instructions

## (1) General Bypass

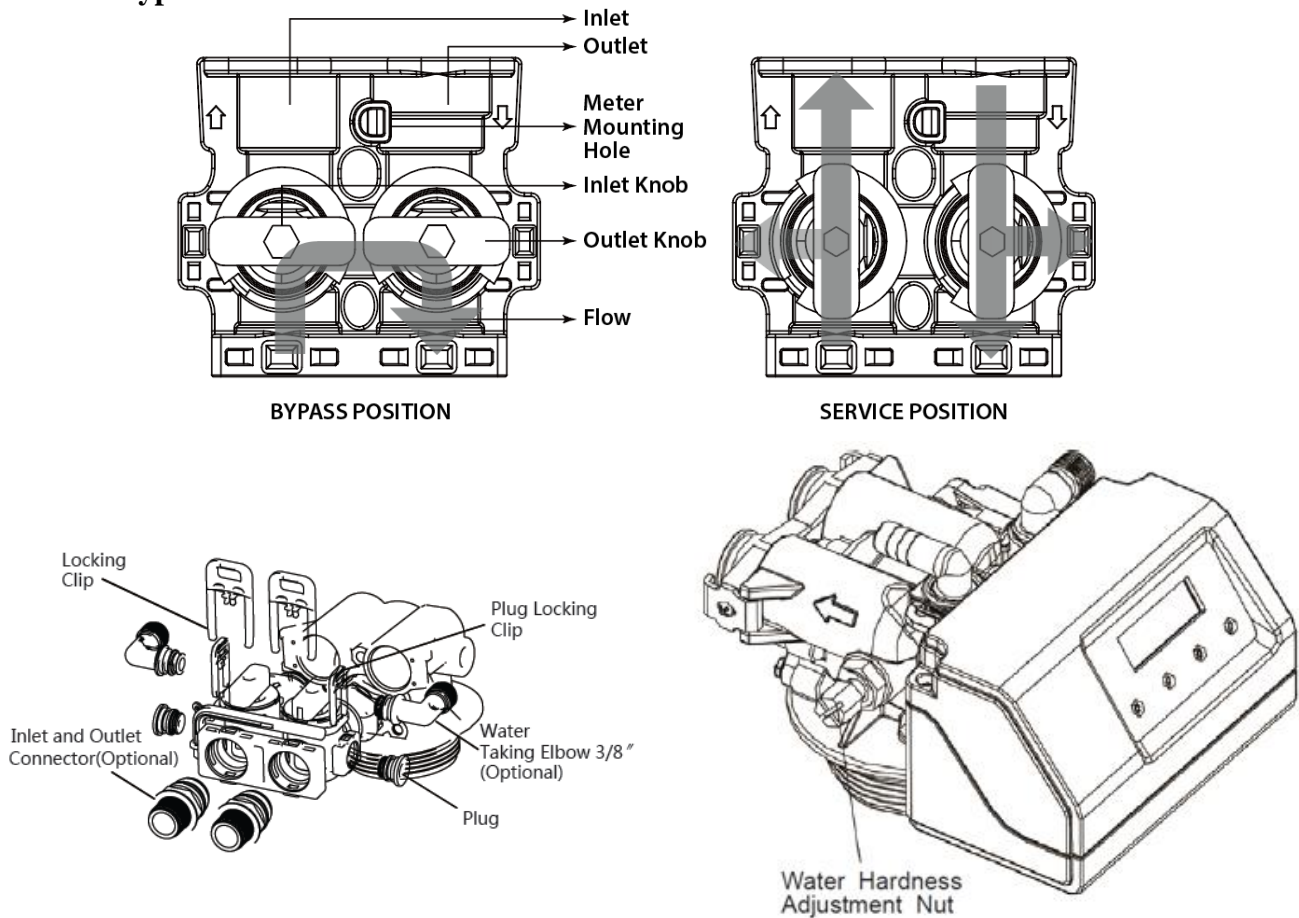

- Hold the knob or use a bypass tool to rotate the knobs. The water supply will be **bypassed** when the knobs are **horizontal**. The bypass valve is in **service** when knobs are oriented **vertically**. When the bypass valve is in service, users can take raw water and filter water samples for testing at the water-taking port on either side of the bypass.
- In case of equipment failure or other exceptional circumstances, the bypass can be adjusted to the bypass position, allowing users to use tap water temporarily. After the failure or problem is resolved, adjust the bypass to the vertical service position.
- Users can adjust the Water Hardness Adjustment Nut to achieve their desired water hardness.
- Rotate the Water Hardness Adjustment Nut in a clockwise direction. The bigger the rotation angle, the higher the water hardness.

## (2) Before Installation

- Verify the water source pressure; the acceptable range is 21 psi - 64 psi. If the pressure is higher or lower than this, it is recommended to install a pressure stabilizer.
- Do not remove the clips when the system is in operation; relieve the pressure before removing the clips.

## (3) Equipment Installation

It is highly recommended that you watch the video *How to Install iSpring WCS45KG Whole House Water Central Softener / DIY Installation* on YouTube.

**Step 1.** Confirm proper installation conditions, unpack the equipment and verify that all accessories are present. Prepare the installation tools and confirm that the installation site's water inlet and outlet pipes, power supplies, drain tube, and floor drain meet the appropriate requirements.

**Step 2. Close the main water supply** completely, then **open any faucets** in the room to remove the remaining water in the indoor water pipe.

**Step 3.** Use a screwdriver to unscrew the two screws on the back of the machine. At this time, you can lift the black lid, unplug the cable on the control panel, and remove the entire lid.

**Step 4.** Add salt to the brine tank. Add sufficient softening salt to the brine tank, or about 2/3 of the brine tank volume.

**Step 5. Lubricate** the inlet/outlet connect screw **o-ring**.

**Step 6.** Connect two one-inch quick-connectors, pull out the clamps, insert the quick-connectors into the water inlet and outlet, and re-insert the clamp.

**Step 7. Connect** the water **inlet** and **outlet** pipes of the system to the pipeline.

Double check the direction of the water flow matches the sign on the system. Pay attention to the pipeline's height and placement angle when connected to prevent the connection pipes from bearing stress. While connecting pipes, keep the pipes as close to the wall as possible. The routing of the pipes should be straight, and the corners should be clear. The pipes should be fixed on the wall after installation.

**Step 8.** Take the drain hose (the original drain hose is 8.6 ft. long) and cut it into two pieces, one for drain and one for overflow. Each section should be about 4.3 ft. long.

**Step 9. Connect** the **drain** hose and **clamp** to the system tightly to ensure a secure connection.

**Connect** the equipment **overflow** hose and **clamp** it to provide a secure connection. The other end of the drain hose and overflow hose goes to the **sewage** pipe.

There must be sufficient space (~10 cm) between the outlet of the drain hose, overflow hose, and the sewage level to prevent sewage from flowing back to the product. The sewage pipe should be 30 cm higher than the ground, and the drain hose should be fixed on the sewage pipe.

**Step 10.** Re-attach the lid. The machine's cable needs to be plugged back into the control panel. Ensure it does not fall off.

**Step 11.** Plug in the **power adapter** and connect the other end of the socket to supply power to the system.

**Step 12.** Rotate the bypass valve knobs to the **bypass position**.

**Step 13.** Slowly **turn on the main water supply**.

**Step 14. Open a cold water tap** nearby and let the water run for a few minutes till the water runs clean or until the system is free of foreign material caused by plumbing work. Then **close the tap**.

**Step 15.** Resin tank flushing process:

**Start regeneration** and slowly **open the water inlet knob** on the bypass valve. The valve should be opened at about 45° (rapid opening will cause equipment damage and resin loss). Wait for the "**BACKWASH**" text on display to stop flashing and start to count down, then **unplug the power supply**, and keep the device in the backwash state.

After the air in the resin tank is wholly discharged (the exhaust sound disappears, and water steadily flows out of the drain hose), **completely open the water inlet valve** and flush the resin

tank until the water is completely clean. The flushing time should not be less than 10 minutes, and the tank's air should be completely exhausted.

✚ **All keys will lock after 3 minutes during standby. Press and hold the "MENU" or "SETTINGS" key for 3 seconds to unlock.**

*Step 15. a.* To perform the **regeneration processes**, press and hold the "SET/REGEN" or "MANUAL REGEN." key for **3 seconds** in the unlocked state to enter manual regeneration mode.

*Step 15. b.* Press the "SET/REGEN" or "MANUAL REGEN." button again to select "IMMEDIATE REGENERATION".

*Step 16.* Add water to the brine tank:

After completing the above steps, **connect the power supply**. The control valve will continue to run the remaining regeneration steps and return to regular use after completion. This step will take about **one to two hours** to complete. The process will replenish a certain amount of water in the brine tank to ensure the next regeneration's effectiveness and is an essential step.

*Step 17.* After completing the above steps, let the equipment **stand for 24 hours** to produce enough concentrated brine in the brine tank. Set the water inlet valve to the **bypass position**.

*Step 18.* Resin regeneration:

24 hours later, **reopen the water inlet valve**. Then start a complete regeneration process to ensure that the resin meets the requirements of regular use. **Start the regeneration**, and the valve will begin automatically running the regeneration process. During this period, do not cut off the water or power, and do not touch any buttons on the valve (be sure to follow the procedure through the entire regeneration process and return to regular use).

✚ **All keys will lock after 3 minutes during standby. Press and hold the "MENU" or "SETTINGS" key for 3 seconds to unlock.**

*Step 18. a.* To perform the **regeneration processes**, press and hold the "SET/REGEN" or "MANUAL REGEN." key for **3 seconds** in the unlocked state to enter manual regeneration mode.

*Step 18. b.* Press the "SET/REGEN" or "MANUAL REGEN." button again to select "IMMEDIATE REGENERATION".

*Step 19.* Rotate the bypass valve knobs to the **service position** and observe whether there is water leakage or any other leakage at each connection.

*Step 20.* **Open a cold water tap** nearby and let the water run for at least 5 minutes or until the water is clear. Then **close the tap**. Verify that the water is completely clear before use.

*Step 21.* Check again for any water leakage in the pipeline and whether the fittings at the connection parts with the original pipeline cause loosening or water seepage from construction.

*Step 22.* Set up the system parameters of the equipment (see [Programming the Central Water Filtration System](#) for details, page 12-15).

*Step 23.* Clean the installation site.

## Operation Tips

- The product can be generally used after installation and commissioning have been completed. With an uninterrupted power supply, the user does not need to perform other operations on the machine.
- The automatic regeneration start time default is to start late at night. The water is not treated and should not be used during this time.
- During the use of the water softener, do not cut off the power to avoid errors in the clock on the water softener, which will affect the original regeneration start time and lead to the potential use of unsoftened water.
- When the water supply is shut down, the water softener should be in the bypass position. When the water supply is restored, the faucet in the home should be opened first. When the water supply is restored after the water supply is shut down, pollutants in the water pipe may enter the water softener and damage the machine, leading to ion exchange resin failure. The contaminated water should be released, and the system should return to the service position after the water runs clear.
- DO NOT regenerate any other softeners/filters at the same time as this system since this will interfere with the regeneration process and cause damage.

## Programming the Central Softener System

### (1) Button Configuration

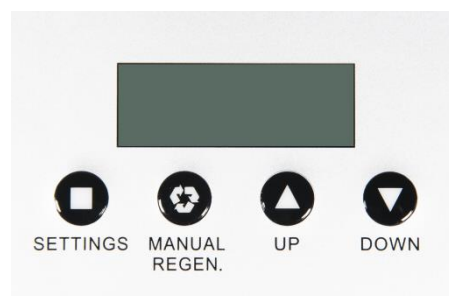

- a. "Menu" or "SETTINGS"  
This function is used to enter the basic setup information required during installation.
  - Press and hold the key for 3 seconds to unlock the device while in standby mode.
  - In the user menu setting, press this button to exit the menu immediately.
- b. "Set/Regen" or "MANUAL REGEN."  
This function is used to initiate an immediate or delayed manual regeneration.
  - In the user menu setting, press this button once to confirm the parameter setting and switch to the next option.
- c. "UP" / "DOWN"  
These buttons are used to increase or decrease the value of the settings while in programming mode.
  - When the display is in a menu option, these keys can be used to adjust the value or option.

### (2) Notes

- a. During the menu setting process, if there is no activity within 1 minute, the system will automatically return to the standby state.
- b. All keys will lock after 3 minutes during the standby status. Press and hold the "Menu" or "SETTINGS" key for 3 seconds to unlock.

### (3) Programming Levels

There are four levels of the valve program:

#### a. Settings

Press and hold "Menu" or "SETTINGS" for 3 seconds to enter.

Use the "UP" and "DOWN" buttons to modify the value. Press the "Menu" or "SETTINGS" button once to confirm and switch to the following parameter setting, the entire menu shown below. Press "Set/Regen" or "MANUAL REGEN." to immediately return to the standby state.

<b>TIME OF DAY</b> 12:01 PM
<b>YEAR</b> 2022
<b>MONTH</b> AUGUST
<b>DAY</b> 21
<b>SET HARDNESS</b> 20.0 gpG
<b>SET PEOPLE</b> 4
<b>SALT SETTING</b> HIGH EFFICIENCY STANDARD IRON & MN
<b>WATER SOURCE</b> MUNICIPAL WELL / OTHER
<b>REGEN. TIME</b> 02:00 AM
<b>LOAD DEFAULT</b> NO
<b>PROGRAMMING</b> COMPLETE

#### **TIME OF DAY, YEAR, MONTH, DAY:**

Time of day is for normal operation and the scheduling of the regeneration time. The date is used in a diagnostic function to track the last time the system regenerated.

#### **SET HARDNESS:**

This value is the maximum compensated water hardness of the raw water supply in grains per gallon. It is used to calculate the system capacity. If Ferrous Iron is present, add 4 gpG for every 1 ppm of Ferrous Iron.

#### **SET PEOPLE:**

This value is the number of people living in the home. It is used to calculate the amount of water needed for daily use and the reserve capacity of the system.

#### **SALT SETTING:**

There are 3 settings to choose in the MENU SETTINGS. High Efficiency, Standard Capacity, and IRON & MN. These settings will determine the salt dosage and capacity for the system.

#### **WATER SOURCE:**

This setting will determine if the BACKWASH OVERRIDE function will be on or off. Select MUNICIPAL if the water source is clean (< 1 NTU turbidity) and the system will skip the backwash cycle based on the setting in BACKWASH OVERRIDE.

Select WELL / OTHER if any Iron or Manganese is present or if the water source is not clean (> 1 NTU turbidity). The system will back wash every time.

#### **REGEN TIME:**

Determines the time of day to perform a scheduled regeneration. You can set the system's regeneration time according to your routine or schedule. It is recommended to set it in a period when water is not in use. The system defaults to 02:00 a.m.

#### **LOAD DEFAULT:**

If the selection is made, the processing time of each regeneration cycle will be reset to the default value setting. The rinse time will return to the default value.

## b. Factory Options

Press and hold "Menu" and "Set/Regen" or "SETTINGS" and "MANUAL REGEN." at the same time for 3 seconds to enter.

Press "Set/Regen" or "MANUAL REGEN." to confirm and switch to the following parameter setting, the entire menu shown below. Use the "UP" and "DOWN" buttons to modify the value. Press the "Menu" or "SETTINGS" button to return to the standby state immediately.

LANGUAGE ENGLISH FRENCH
UNITS GALLONS METRIC
HARDNESS UNITS gpG
HIGH EFFICIENCY 3.0 lbs/CUFT
HIGH EFFICIENCY 5000 GRAINS
STANDARD 6.0 lbs/CUFT
STANDARD 4150 GRAINS
IRON & MN 12.0 lbs/CUFT
IRON & MN 2500 GRAINS
REFILL FLOWRATE 0.30 gpM
BRINE MAKE TIME 30 MINUTES
BRINE PRE-FILL% 70%
DAILY RESERVE 4 DAYS AVERAGE
DAY OVERRIDE OFF
RINSE OVERRIDE OFF
BW. OVERRIDE 10 REGENS
FORCED REGEN. OFF
SMART CLEAN OFF
PROGRAMMING COMPLETE

### **SYSTEM LANGUAGE:**

Choose the system language.

### **UNITS:**

Choose the system's unit of measurement: metric or gallons.

### **EFFICIENCY & CAPACITY SETTINGS:**

There are 3 settings to choose from: High Efficiency, Standard Capacity, and Iron & Manganese. The values for these settings are set in the Factory Options and are used to calculate the system capacity and refill time.

### **REFILL:**

This value should match the BLFC flow washer. It is used to calculate the refill time.

### **BRINE MAKE TIME:**

This value is the time allowed for the salt to dissolve in the water to create the brine solution. It is the amount of time ahead of the scheduled regeneration time that the water will be added to "top off" the brine already prepared in the brine tank.

### **BRINE PRE-FILL%:**

This is the percentage of water that will be added to the brine tank after a regeneration. The default is 70%. The remaining water will be added just prior to the regeneration and will be proportional to the amount of capacity left in the system.

### **DAILY RESERVE:**

This value is used to calculate the reserve capacity. Reserve Capacity = # of People x DAILY RESERVE. The 4-day option is used to calculate the daily water consumption for 28 days, and the average daily water consumption for each day of the week is calculated separately.

### **BW. (RINSE) OVERRIDE:**

This setting can be used to skip the backwash (rinse) cycle. As an example, if the setting is 10, the system will skip 10 backwash (rinse) cycles. The setting will only work if the WATER SOURCE is set to MUNICIPAL for clean water applications.

### **FORCED REGEN:**

When set to ON, the system will start a forced regeneration when the remaining capacity reaches 3% and when no water is used for 10 minutes. The regeneration consists of 20 minutes of Brine and 10 minutes of Rinse. The 30 minute regeneration will restore up to 33% of the system capacity. At the next regeneration time (2:00 a.m.), the system will automatically perform a standard regeneration to restore capacity to 100%.

### **SMART CLEAN:**

When set to ON, the system will perform a 10 minute (adjustable) backwash and rinse if there is no water flow detected after 7 days (adjustable). The regeneration will occur at the scheduled REGEN TIME.



**c. Advanced Options**

Press and hold "UP" and "DOWN" at the same time for 3 seconds to enter. Press "Set/Regen" or "MANUAL REGEN." to confirm and switch to the following parameter setting, the entire menu shown below. Use the "UP" and "DOWN" buttons to modify the value. Press the "Menu" or "SETTINGS" button to return to the standby state immediately.

<b>RESIN VOL.</b> 1.25 CF
<b>SALT SETTING</b> HIGH EFFICIENCY
<b>BACKWASH</b> 4 MINUTES
<b>BRINE</b> 90 MINUTES
<b>RINSE</b> 8 MINUTES
<b>REFILL</b> AUTO 4.2 MIN
<b>LOCK VALUE</b> UNLOCK
<b>PROGRAMMING</b> COMPLETE

<b><u>UNIT SIZE:</u></b> The "RESIN VOL." is the amount of ion exchange media used in the system.
<b><u>CYCLE SETTINGS (BACKWASH, BRINE, RINSE):</u></b> The system has pre-engineered default settings for every valvemode, unit size, and salt setting. The settings are optimized to maximize salt and water use efficiency. The settings can be manually adjusted. Users can adjust these parameters at any time with the help of an application engineer based on the water environment. Refill is automatically calculated.
<b><u>LOCK VALUE:</u></b> This setting locks the value set in the previous page, and the end user will not be able to modify it before the setting is changed to UNLOCK.

**d. Regeneration Mode Options**

Press the "Set/Regen" or "MANUAL REGEN." button once to enter the "DELAYED REGEN." function. Use the "UP" and "DOWN" buttons to change the mode. Press "Set/Regen" or "MANUAL REGEN." to confirm the setting. Press the "Menu" or "SETTINGS" button to return to the standby state immediately.

<b>DELAYED REGEN.</b> OFF
------------------------------

<b><u>DELAYED REGENERATION</u></b> In this mode, the system will start a regeneration at the next regeneration time regardless of the remaining regeneration days or water consumption.
--

Press and hold the "Set/Regen" or "MANUAL REGEN." button for 3 seconds to enter the "REGENERATION" setting. Use the "UP" and "DOWN" buttons to switch the modes. Press "Set/Regen" or "MANUAL REGEN." to confirm the setting. Press the "Menu" or "SETTINGS" button to return to the standby state immediately.

<b>REGENERATION</b> IMMEDIATELY
<b>REGENERATION</b> VACATION MODE

<b><u>IMMEDIATE REGENERATION</u></b> Under this mode, the system immediately starts a regeneration.
<b><u>VACATION MODE</u></b> Choose vacation mode and input estimated holiday days; the valve will regenerate in a SMART CLEAN mode. The system will remain in vacation mode when no water is used during the input estimated holiday days; if there's water used, the vacation mode will be auto-off, and the system will return to the normal working mode.

## **Emergency Response**

- If the equipment fails or experiences other exceptional circumstances, the inlet and outlet valves can be closed (bypass position), and the municipal water supply can be used directly. Reopen the system's water inlet and outlet valves once the emergency is fixed.
- If water consumption increases significantly (relative to normal usage) or the hardness of raw water increases, the number of regenerations should be increased accordingly. The softening capacity of the water softener in actual use is related to the quality of the raw water and is associated with the softener's water flow rate. The flow rate should be appropriately low when in use, which will better affect water softening.
- During the process of system regeneration, if the system experiences a power loss, more than one discharge may occur, resulting in the waste of water resources.
- In case of power failure, readjust the current time and regeneration start time according to the manual after the power supply is restored.
- When the water supply in a residential area is shut down, the main water main valve should be closed immediately. The municipal water supply may cause negative pressure on the household pipeline and damage the equipment.

## **Maintenance**

- Regularly get your water tested to ensure the system is working properly.
- Media needs to be refilled only when the system reaches capacity or accidentally gets contaminated. The media replacement process needs to be conducted with a professional or under professional guidance. For related questions, contact the iSpring Customer service team.
- Systems installed outdoors without regular maintenance will fail sooner than those installed indoors. It is recommended that you check the product and maintain it regularly. Call us immediately if anything goes wrong.
- Do not operate this equipment if you have not read and truly understood this manual.
- The effluent during the regeneration process is not softened, and the water used during the softener regeneration will affect its regeneration effect. It is not recommended to use the water at this time.
- If the equipment fails or experiences other exceptional circumstances, the inlet and outlet valves can be closed (the bypass valve is open), and the municipal water supply can be used directly. After removal, open the water inlet and outlet valves of the device.
- Once the water softener has been stopped for a while, a regeneration operation should be added to ensure the quality of the softened water before reuse.
- Hot water will cause severe damage to the water softener's internal system; therefore, users who need to connect a water heater behind the water softener should ensure there is at least a three-meter tube between the outlet of the water softener and the inlet of the water heater. If the three-meter connecting pipeline cannot be guaranteed, installing a check valve between the water softener and the hot water heater is recommended.
- Only silicon-based grease should be used for maintenance. Any other grease formulations will affect the working life of the water softener.
- During regular use of the bypass, do not pull out the clamp. The pressure must be released before the clamp is removed.
- An overflow pipe must be used when installing this product to ensure safe use.
- Check the condition of the water softener regularly. Users should inspect the following:
  - a) Whether there is any leakage in the pipeline. If so, contact iSpring.
  - b) Whether the overflow pipe is blocked. If so, clear it in time.
  - c) Whether the brine tank is vertical. If so, straighten it in time.
  - d) If the amount of salt is lower than the water level. If so, add salt in time.
- Use softening granular salt for the water softener, and avoid using small granular, fine salt.

## Troubleshooting

ISSUE	POSSIBLE CAUSE	POSSIBLE SOLUTION
<i>The control valve does not work</i>	The transformer is not plugged in	Connect the power supply.
	Socket failure	Repair or replace the socket.
	Power failure	Wait for power to be restored.
	Transformer failure	Replace the transformer.
<i>Incorrect regeneration time</i>	Power failure or loose power plug	Recalibrate the time according to the instructions.
<i>Leaking water</i>	Loose connection	Tighten the connection or reconnect.
<i>Noise in equipment</i>	Air is entering the equipment	Backwash again, exhaust air.
<i>The effluent contains bubbles</i>	Air is entering the equipment	Backwash again, exhaust air.
<i>No softened water</i>	No salt is added to the brine tank, or the brine concentration is too low	Add salt.
	The brine suction pipeline is blocked	Remove blockages.
	Inlet water pressure is too low	Increase the inlet water pressure, which should be greater than 21 psi.
	Brine pipeline leak	Check all components of the brine suction pipe and eliminate the leakage point.
	No salt	See the "No salt absorption" troubleshooting method for details.
<i>No salt absorption</i>	The regeneration device does not work	Check controller power.
	Injector net blocked	Clean the injector net.
	Blocked injector	Disassemble the injector net, rinse with water to remove blockages, and reinstall.
	Blocked brine valve	Remove the blockage or replace the brine valve.
	Blocked brine suction orifice	Remove the brine suction orifice plate and rinse with water to remove the blockage, then reinstall.
<i>Backwash flow is too high or too low</i>	Improper use of flow control	Replace with suitable flow control.
	Foreign matter in the flow control	Remove foreign objects.
<i>The effluent water has High hardness</i>	Low quality from the water source	Contact iSpring.
	Incorrect regeneration cycle setting	Reset the regeneration cycle according to the manual.

	The water hardness adjustment nut is leaking or opened too far	Close the water hardness adjustment nut or readjust the flow of the water hardness adjustment nut.
	Bypass leaking	Replace the gasket.
<b><i>Brine tank overflow</i></b>	Replenishment time is exceedingly high	Reset the replenishment time.
	The machine is leaking	Turn off the machine and contact iSpring.

**Need help with troubleshooting?** If you have any questions or find there are missing parts or

damage, please call **1-678-261-7611** or visit **[www.ispringfilter.com](http://www.ispringfilter.com)**

When calling, please be prepared to provide the model of your product.

(The model of this product is "WCS45KG".)

## **iSpring Standard Limited Warranty (End-Users Only)**

**In order to be eligible for this warranty, the end-user must register at [www.123filter.com](http://www.123filter.com).**

For all water filtration systems, and upon registration by the end-user, iSpring Water Systems, LLC (iSpring) warrants for a one year from the date of purchase that the product is free of defects in materials and workmanship and that it will function for the duration of the warranty according to its specifications (the "Limited Warranty"). EXCEPT FOR THIS LIMITED WARRANTY, ISPRING EXPRESSLY DISCLAIMS ANY AND ALL REPRESENTATIONS AND WARRANTIES, WHETHER EXPRESS, IMPLIED, OR STATUTORY, INCLUDING ANY WARRANTIES OF TITLE, NON-INFRINGEMENT, MERCHANTABILITY OR FITNESS FOR A PARTICULAR PURPOSE. iSpring has no liability for any defect or deterioration which results from the improper installation, service, repair or use of the product. End-user's sole and exclusive remedy for any breach of the Limited Warranty shall be repair or replacement, at iSpring's option and expense. This warranty is only provided to end-users and only applies to products purchased directly from an authorized iSpring dealer or reseller.

However, we do not have the order information from websites other than 123Filter.com (Amazon, Home Depot, etc.), so please be sure to fill in that information upon registration of your system. If you have any questions or concerns about your product, please do not hesitate to call or email us, or put it in the notes/comments upon your warranty registration. Your satisfaction is our business!

If you are happy with our products and service, please show your support by writing a product review on Amazon, even just a single line. It takes you just a minute but means a lot to us. Thank you!

## Warranty Registration Form

Name \_\_\_\_\_ Order# \_\_\_\_\_

Email \_\_\_\_\_ Phone \_\_\_\_\_

Address \_\_\_\_\_

City \_\_\_\_\_ State \_\_\_\_\_ Zip Code \_\_\_\_\_

Model #/ Serial Number

\_\_\_\_\_

Purchased at (e.g. Amazon, Home Depot)

\_\_\_\_\_

iSpring Water Systems, LLC  
2480 Industrial Park Blvd, Cumming, GA 30041  
678-261-7611

Plumber's information (Optional)

To best serve our customers, we'd like to recommend good plumbers throughout the USA. If you are happy with your installer, please provide their information so that we can pass it on as a courtesy.

Thank you!

Name of the plumbing company used to install your system:

\_\_\_\_\_

Phone #: (\_\_\_\_\_) - \_\_\_\_\_ or email : \_\_\_\_\_  
of the technician.





Like our products?  
Please show your support by writing a product review on the marketplace where you make your purchase. Even just a quick statement means a lot to us.

Thank you!

**iSpringFilter.com**

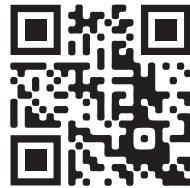

For questions, comments, or technical support, please contact us at:

✉ [support@123filter.com](mailto:support@123filter.com)

☎ +1 (678) 261-7611

💬 +1 (470) 560-0012

Monday-Friday 8:30 a.m. - 5:30 p.m. EST

**Water's Good™**

---