

WATER DISPENSER

iSpring DS4S Free-standing Dispenser with Built-in 4-Stage Filtration

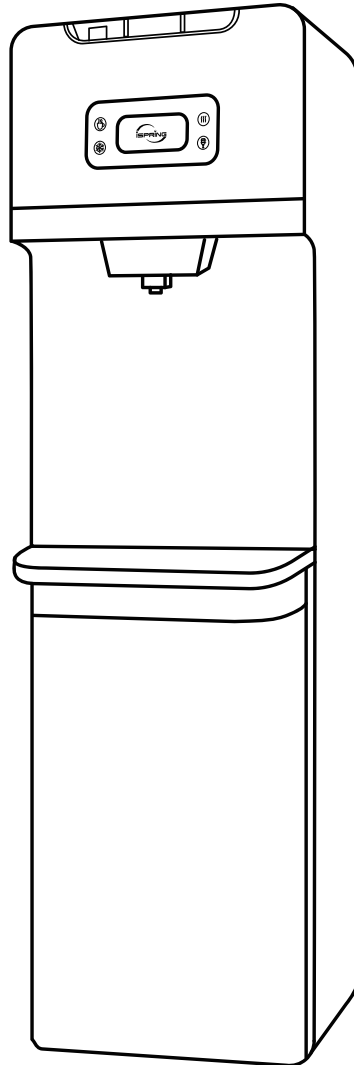

Installation Instructions & User Manual

Ver. 11/2022



Copyright ©2005-2022 ISPRING WATER SYSTEMS, LLC. All rights reserved.



We stand behind our products

Since 2005, iSpring has been dedicated to providing high-quality drinking water to families across the United States. We provide various residential faucets and water filtration systems that purify your water in everyday life and deliver pure, healthy, and tasty water to you and your family.

At iSpring, we strive to develop products to the highest of standards and aim to make excellent drinking water accessible for all households. With affordable pricing, reliable quality, prompt delivery, and top-notch customer service, we hope to assist in bringing you great water for years to come.

Prior to Installation

Read this instruction manual carefully prior to installation.

Keep this manual readily available for future reference.

Table of Contents

User Information	3
Product Operation & Specifications	4
Before You Start	4
System Parts Identification	6
<u>Using the System</u>	
Control Panel LED Light Functions	7
Operation.....	8
Care and Cleaning	11
Troubleshooting	13
<u>Warranty</u>	
Warranty and Registration	14

User Information

The user must adhere to the installation specifications described in this Product Installation and Operation Manual (hereinafter referred to as the "instruction manual"). iSpring is not responsible for damage, loss, or injury resulting from neglect, improper maintenance, or unauthorized modification of the unit.

- The unit should be placed only on flat surfaces. Do not mount on a wall.
- Use only authorized iSpring parts. Using unauthorized or aftermarket components will void the product warranty.
- Unauthorized modification and disassembly are strictly prohibited and will void the warranty.
- Never touch the power cord connector when your hands are wet, as this may result in electric shock.
- Never turn the dispenser upside down or tilt it more than 45 degrees. If the unit has been resting on its side for a long time, place the water dispenser in the upright position for approximately 12 hours before turning it on.
- Never use this dispenser with water that is unsafe to drink or is from an unknown source.
- This water dispenser is equipped with a grounded power cord plug for your safety.
- Keep your water dispenser in a dry place away from direct sunlight.
- Leave a minimum of 2" (5 cm) around the back and sides of the dispenser for proper ventilation.
- Always install your water dispenser on a level floor. Please wait 3 minutes before restarting the machine after shutting it down.
- Always unplug the water dispenser before servicing.
- Regular cleaning of your water dispenser is required for your warranty. Please follow the cleaning instructions outlined in this manual and clean the dispenser every four months.
- The lower front panel must permanently be installed/positioned on the unit for proper operation.

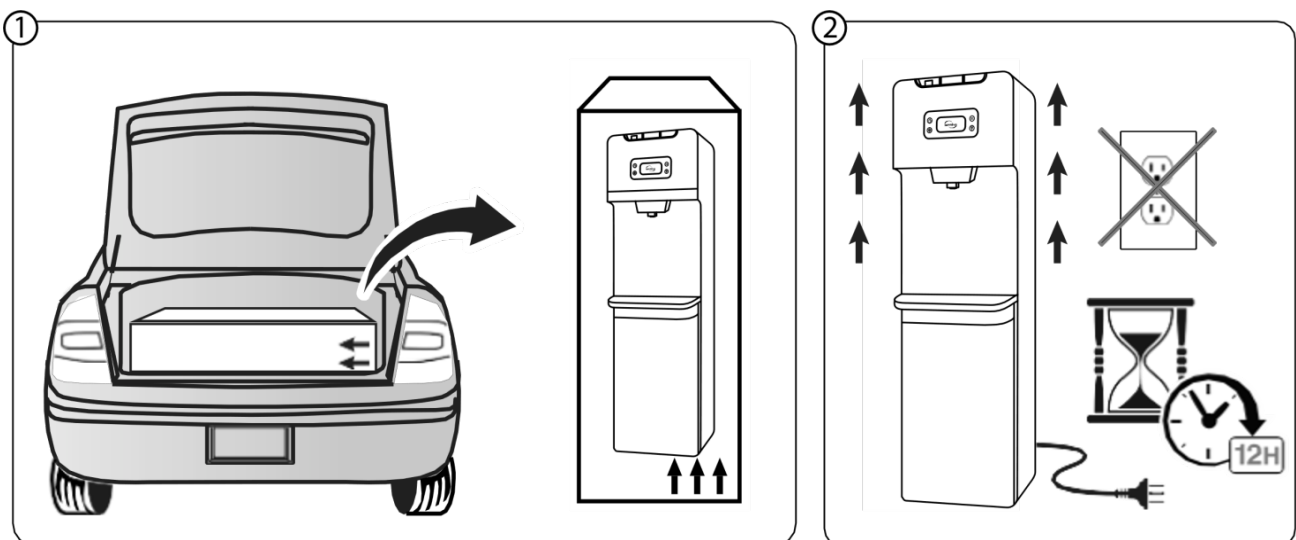

Product Operation & Specifications

Though testing was performed under standard laboratory conditions, the actual performance of the system may vary based on local water conditions and quality.

SPECIFICATIONS	
	Model DS4S
Dimensions W x D x H	11.8 in. x 14.1 in. x 41.7 in. 30 cm x 35.8 cm x 106 cm
Water Inlet Temp.	40-100 °F
Heating Temp (approx.).	194 °F / 90 °C
Cooling Temp (approx.).	41-48 °F / 5-9 °C
Heating Power Consumption	500 W
Cooling Power Consumption	85 W

Filters			
Stage	Model	Purpose	Life
1st	FPDS: PP Filter	High-capacity polypropylene filter. Made with food-grade polypropylene micro-fibers. Removes sediment, dirt, sand, silt, rust, and scale particles.	3 - 6 mo.
2nd	FGKDS: GAC+KDF Compound Filter	Made with high-quality KDF and granular activated carbon. Reduces chlorine, lead, hydrogen sulfide, odors, and other contaminants.	6 - 12 mo.
3rd	FCDS: CTO Carbon Block Filter	Made with high-quality activated carbon. Reduces chlorine, foul odor, and taste. Removes sediment, dirt, sand, and rust.	6 - 12 mo.
4th	FTDS: Post Activated Carbon Filter	Made with high-quality granular activated carbon. Reduces chlorine, foul odor, and taste. Removes sediment, dirt, sand, and rust.	6 - 12 mo.

*Filters life may varies per source water quality.

Before You Start

Failure to follow these instructions can result in death, fire, or electrical shock.



Caution

- Never allow children to dispense hot water without proper and direct supervision.
- Do not plug in or turn on the water dispenser unless there is water in the system.
- Refrigerants must be handled and disposed of by qualified service personnel only. Before discarding this water dispenser to landfill, contact local authorities for advice on proper disposal methods for refrigerants.



Warning

- Never put anything flammable close to the dispenser.
- This water dispenser is designed for indoor applications only.
- Electric shock hazard: Do not overload sockets or extension cords.
- Do not damage the refrigeration cooling system.
- Do not touch the plug with wet hands to prevent electric shock.
- Always disconnect the power cord before attempting to clean or move the dispenser.
- ELECTRICAL REQUIREMENTS:

A 115 Volt, 60 Hz., AC only 15 amperes fused, grounded electrical supply is required. It is recommended that a separate circuit serving only your Water Dispenser be provided. Use an outlet that a switch cannot turn off.

- GROUNDING INSTRUCTIONS:

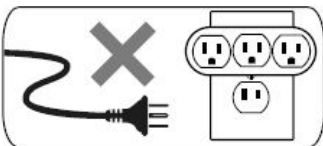
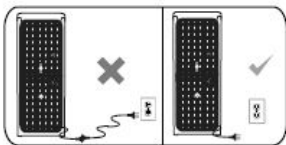
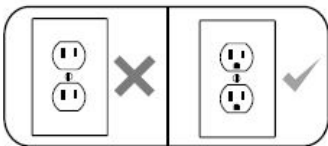

- This appliance must be grounded. In an electrical short circuit, grounding reduces the risk of electric shock by providing an escape wire for electric current.
- Improper use of the grounding plug can result in a risk of property damage, the electric shock causing severe injury, even death.
- This appliance is equipped with a power cord having a grounding wire with a grounding plug and must be connected into an adequately grounded polarized outlet. Consult a qualified electrician if the grounding instructions are not entirely understood or if doubt exists as to whether the wall outlet is properly grounded.
- If the wall outlet is a standard two prong outlet, it is your responsibility and obligation to have it replaced with a properly grounded 3-prong wall outlet.
- Do not under any circumstances cut or remove the third (ground) pin from the power cord plug.
- Do not use adapter plugs or extension cords with this appliance.
- If the power cord is too short, have a qualified electrician install an electrical outlet near the machine.
- Do NOT use the machine if the power cord becomes frayed or otherwise damaged.

For questions or concerns, call **1-678-261-7611** or email Support@123filter.com, or visit www.ispringfilter.com/support.

System Parts Identification

1. Hot Water Push Button (with Child Safety Lock)
2. Room Temperature Water Push Button
3. Cold Water Push Button
4. LED (Ready-to-Dispense Indicator Lights)
 - Red = Hot Water
 - Yellow = Water Levels
 - Blue = Cold Water
5. Door Switch (Controls System Operation)
6. Removable Drip Tray & Grill
7. Filters (1st stage → 4th stage: left → right)
8. Inline Ball Valve (ABV1K)
9. Lower Front Door

NOTE: Door must always be closed for proper operation

10. Leak-detect Sensor
11. Hot Water Switch (red)
12. Adjustable Cold Water Control
13. Drain Line Valve & Cap
14. Power Cord
15. Condenser Coil
16. Water Inlet

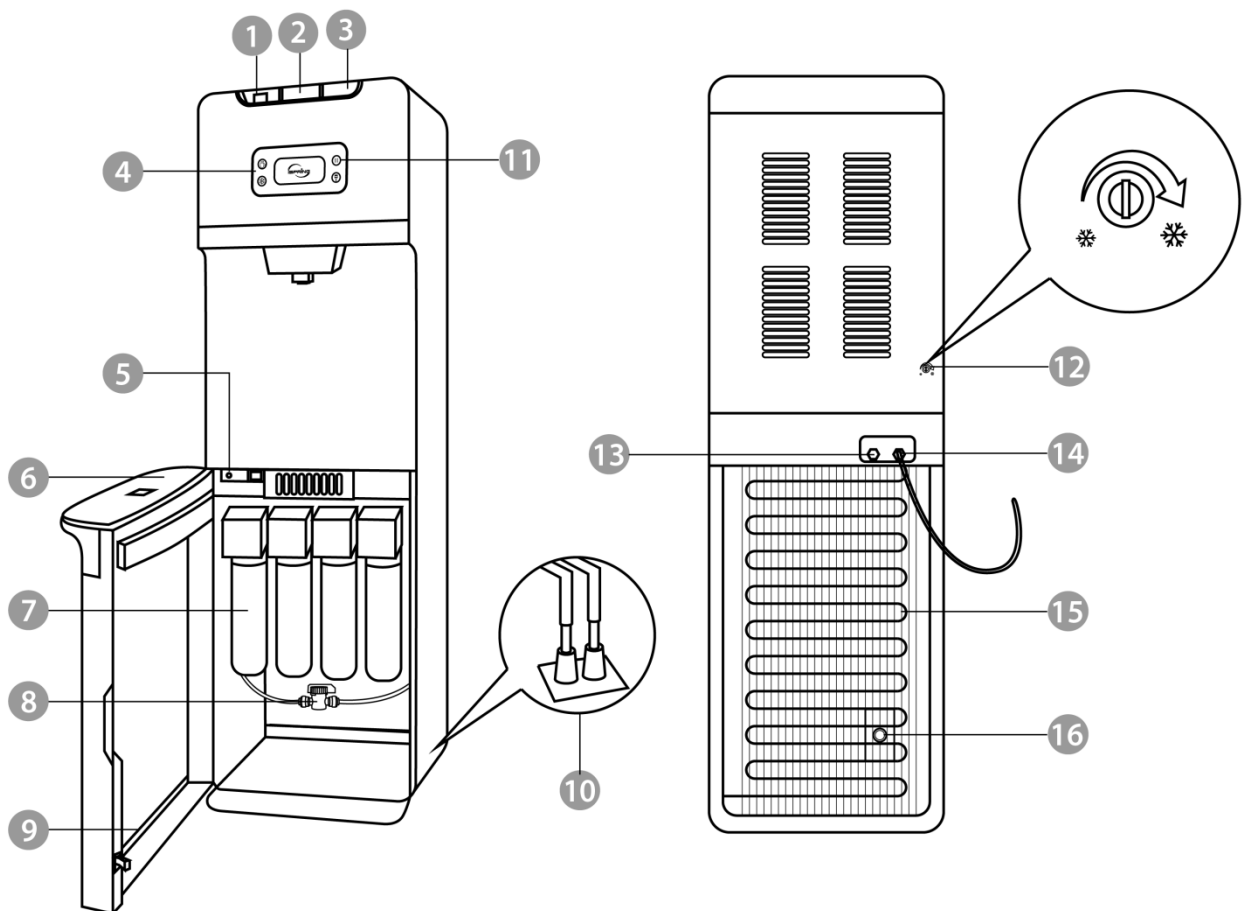

Control Panel LED Light Functions

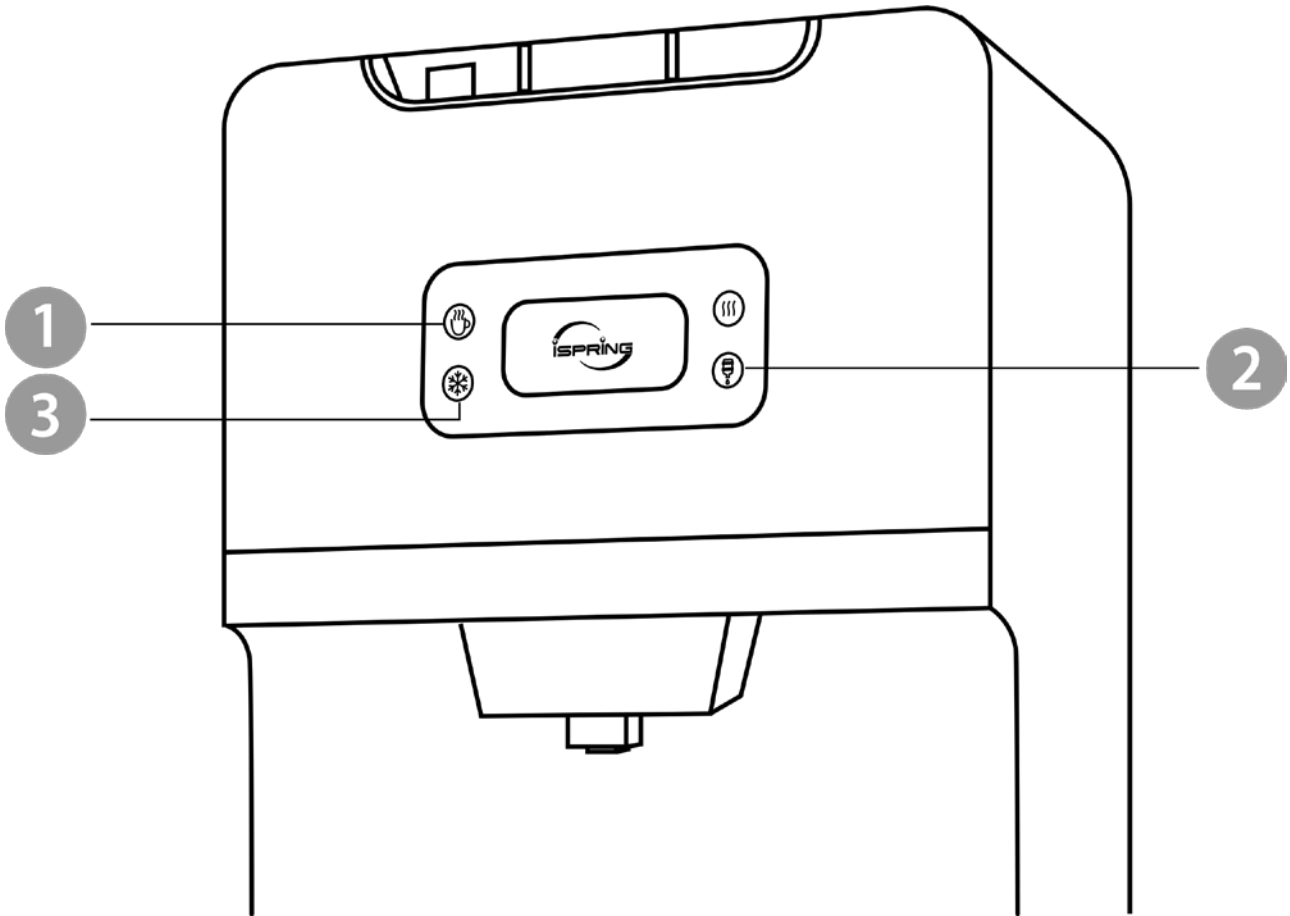

		Off	Flashing	Solid
1	Red LED Light (Hot Water)	The heating system is off. Activate the hot water (red) switch on the panel (page 6 #11).	Hot water is heating.	Hot water has reached optimum temperature, water ready to dispense.
2	Yellow LED Light (Water Level)		Water levels inside the reservoir are low. Check the water inlet and the valves.	Water levels inside the reservoir are normal.
3	Blue LED Light (Cold Water)	The cooling system is off. Connect the power cord (page 6 #14) to an electrical outlet.	The cooling system is cooling.	Coldwater has reached optimum temperature, and the water is ready to dispense.

NOTE: The hot water heating system will not operate during the water level inside the reservoir is low.

Operation

(1) Quick Connect Instruction

HOW TO CONNECT

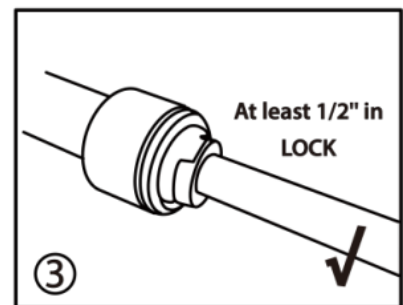
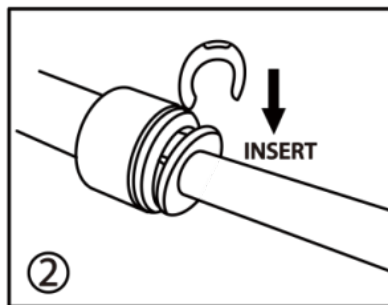
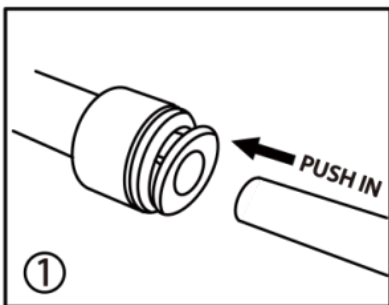

HOW TO DISCONNECT

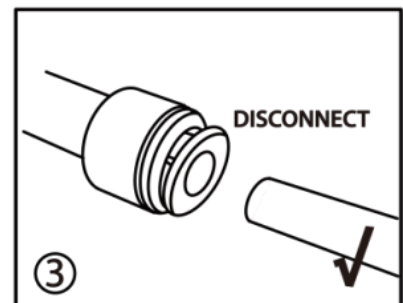
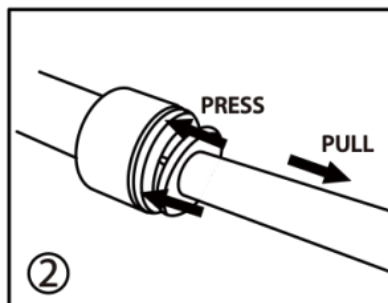
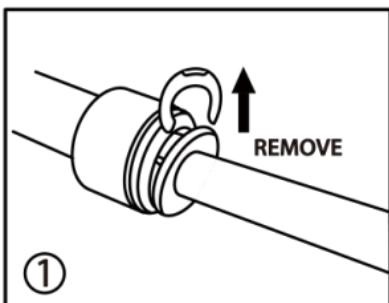

It is highly recommended that you watch the video "**How to Connect and Disconnect Quick Connect Fittings | DIY Installation**" on YouTube.

Cut the tubing end squarely using a utility knife or scissors. Insert the tubing into the quick connect fitting for at least 1/2". You will need to wiggle the tube and apply additional pressure to create a seal.

(2) Install Feed Water Adapter (AFW43) (Optional)

It is highly recommended that you watch the video "**How to Install a Feed Water Adapter for Reverse Osmosis (RO) and Other Applications | iSpring AFW43**" on YouTube.

Step 1. Turn off the Cold Water Supply Valve (CWSV) under the sink and open the kitchen faucet to release pressure. Get a towel or bucket to catch any water drips. Disconnect the kitchen faucet connector pipe from the CWSV.

Step 2. Install the Feed Water Adapter onto the CWSV and tighten it using a wrench or pliers. Make sure the O-ring is seated inside the adapter.

Step 3. Re-install the kitchen faucet connector pipe onto the male end of the Feed Water Adapter. Turn the handle of the Feed Water Adapter to the perpendicular OFF position. Turn on the CWSV slowly, and ensure you get a proper seal.

Step 4. Connect the 1/4" tubing to the Feed Water Adapter.

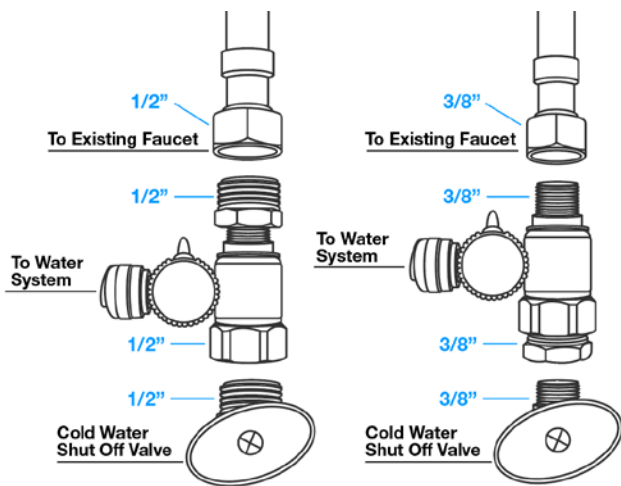

The included bushing can be threaded on either side of the Feed Water Adapter to fit the configuration of both 3/8" COMP and 1/2" NPT.

(3) Installation

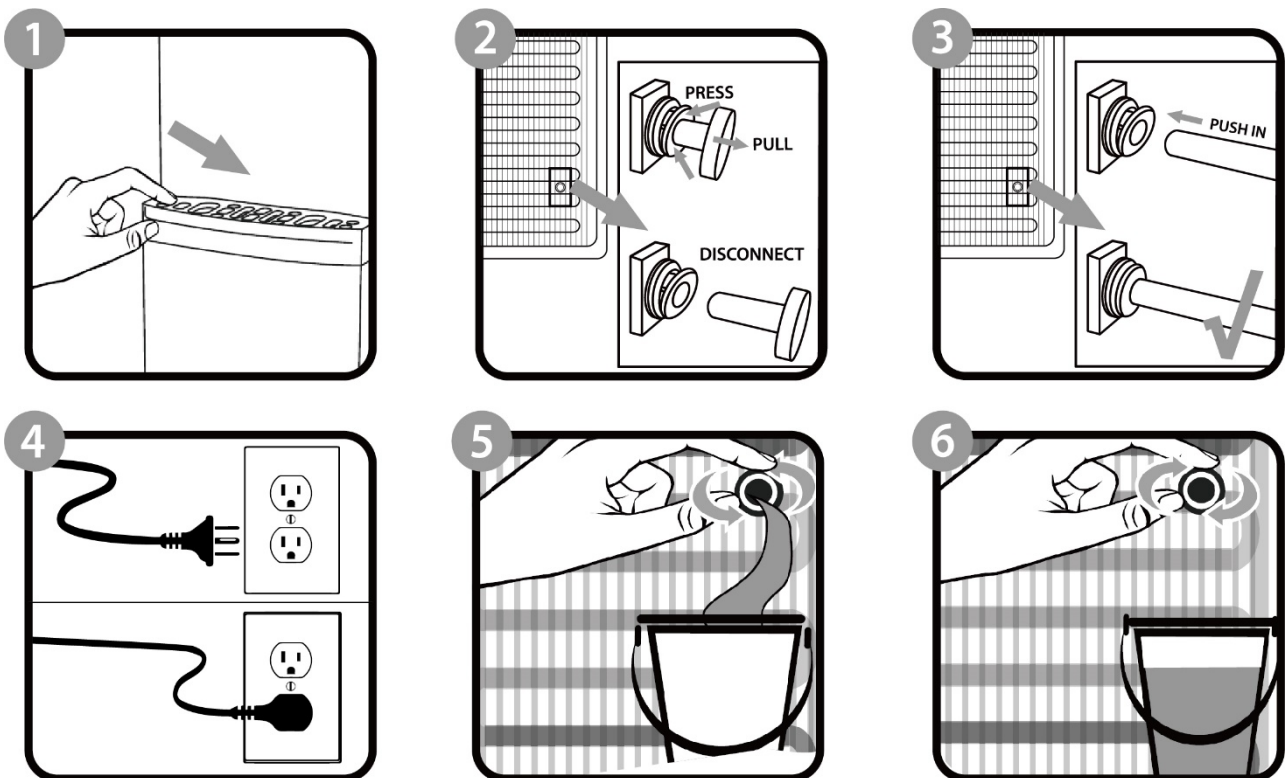

- Step 1.** Choose a suitable location for the system. It must be placed on a flat surface.
- Step 2.** Install the **Removable Drip Tray & Grill** at the **front** of the system.
- Step 3.** Insert the **1/4" tube** into the **1/4" water inlet** (page 6 #16) at the **back** of the system.
- Step 4.** Plug in the **power cord** (page 6 #14) to the power socket at the **back** of the system.
Vibrations can be expected as the system starts.
- Step 5.** Turn the handle of the **Feed Water Adapter** (AFW43) to the parallel **ON** position if installed. Turn **on** the **Inline Ball Valve** (ABV1K) (page 6 #8) slowly if closed, and **close** the **Lower Front Door** (page 6 #9).
- Step 6.** Prepare a bucket, remove **Drain Line Cap** (page 6 #13) at the **back** of the system, and let it run for at least **5 minutes** and **until the water is clean to flush the system**. This should be done each time the filters are changed.
- Step 7.** Once the rinsing is completed, screw back the **Drain Line Cap** (page 6 #13).
- Step 8.** **Activate** the **hot water (red) switch** (page 6 #11) on the panel if you want to turn on the heating system.
- Step 9.** The system is ready for use (see Control Panel LED Light Functions for more details, page 7).

(4) Dispensing Cold Water

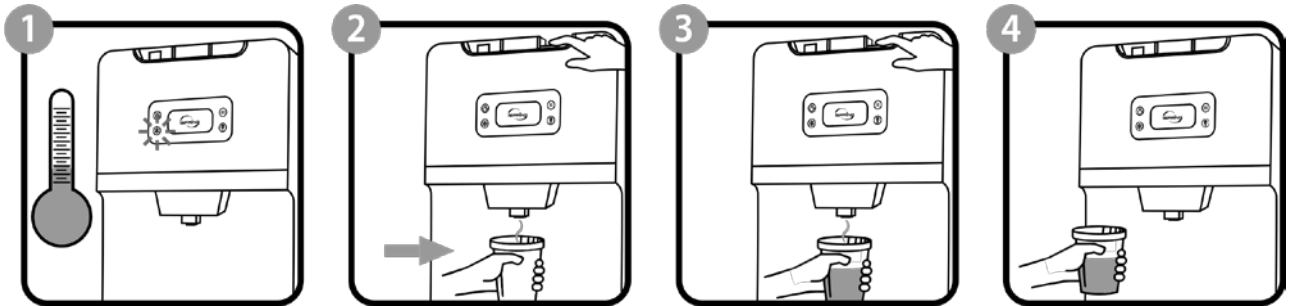

This Water Dispenser left the factory with the cold water temperature control default setting for Energy Star compliance. This setting will deliver cold water temperatures between 4°C - 8°C (39°F - 46°F). The temperature can be adjusted. Using a screwdriver, turn the dial clockwise between "❄️" (cold) and "❄️❄️" (colder) until the desired temperature is reached.



(5) Dispensing Hot Water

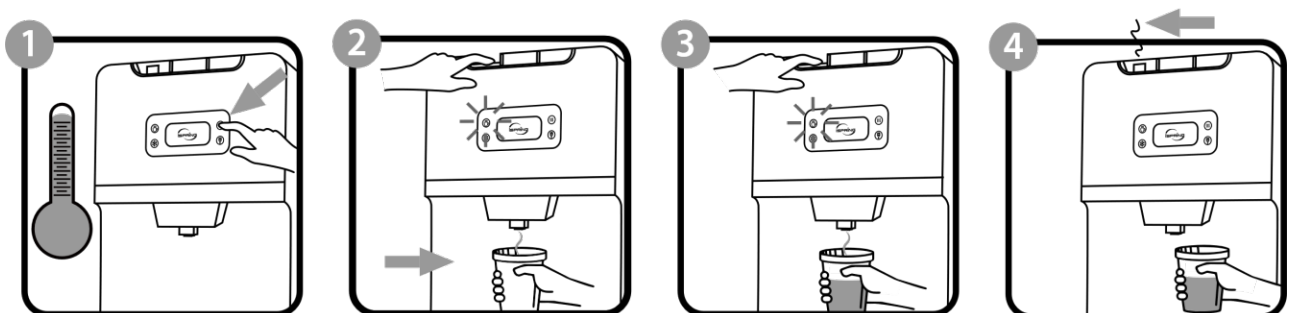

⚠ Warning: Hot water temperatures can reach 94°C/201°F and produce severe scalding. Never let children dispense water without direct adult supervision.

NOTE: The hot water temperature is factory set and cannot be adjusted.

(6) Going Away on Vacation

To conserve energy, unplug the dispenser and drain the reservoirs when not using the dispenser for long periods or when going on vacation (see Draining the Reservoirs, page 11). Follow Initial Product Cleaning Procedures upon return and startup of the dispenser.

Care and Cleaning

■ Cleaning the Outside of the Water Dispenser

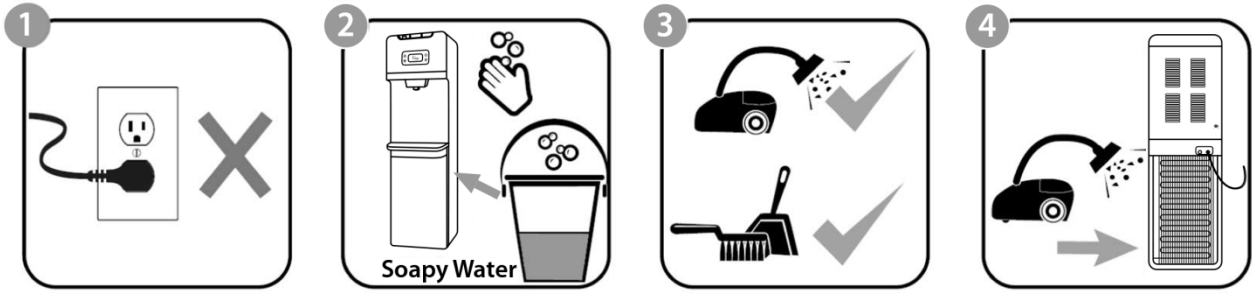

■ Cleaning the Drip Tray

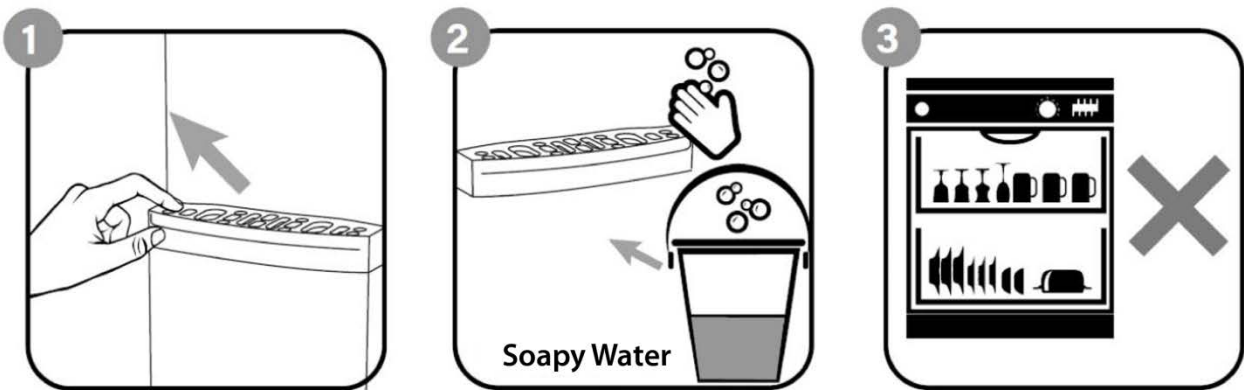

■ Draining the Reservoirs

⚠ Caution: Water May Still Be Hot.

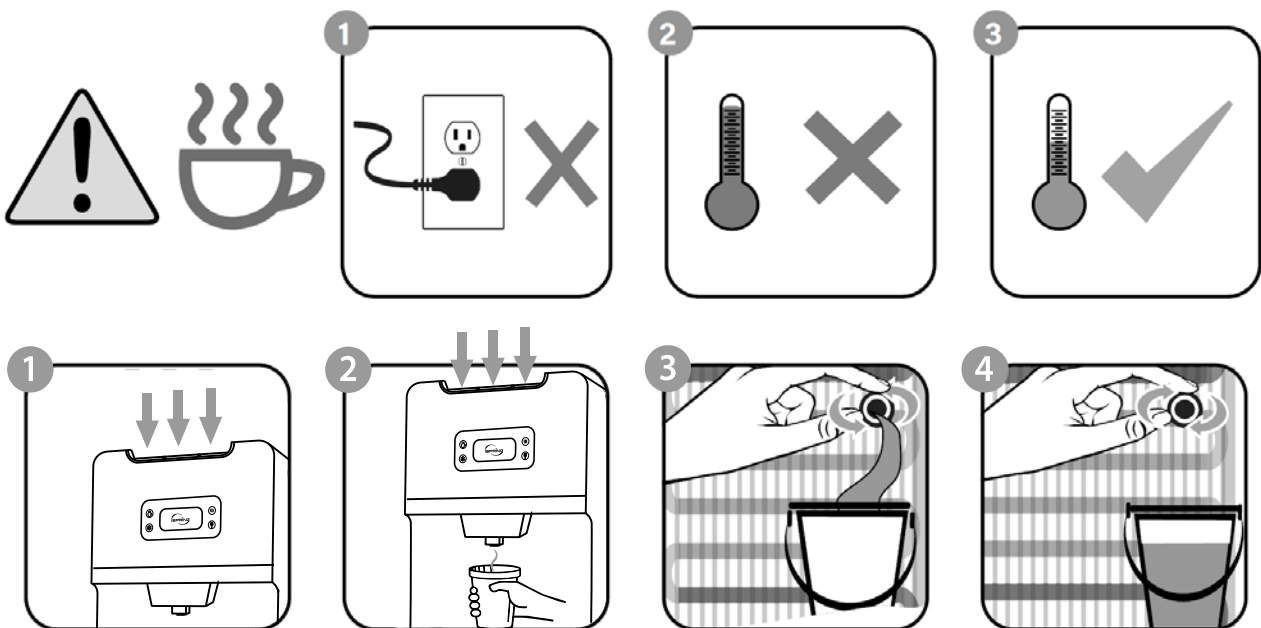

■ **Changing the Filters**

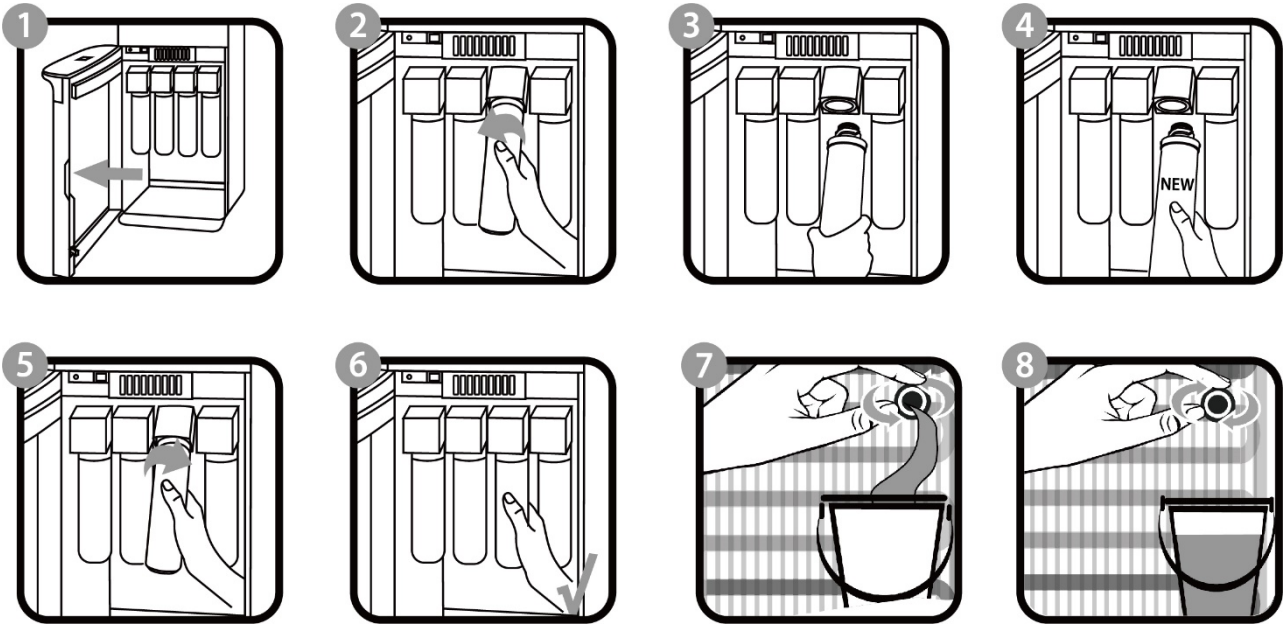

Step 1. Open the Lower Front Door (page 6 #9).

Step 2. Turn off the Inline Ball Valve (ABV1K) (page 6 #8).

Step 3. Drain the Reservoirs. (page 11)

Step 4. Unscrew the filter(s) to be replaced. (turn left)

Step 5. Screw the corresponding replacement filter(s) into each slot. (turn right)

Step 6. Turn on the Inline Ball Valve (ABV1K) (page 6 #8).

Step 7. Close the Lower Front Door (page 6 #9).

Step 8. After replacing the filter, prepare a bucket, remove Drain Line Cap (page 6 #13) at the back of the system, flush the system by running the water for at least 5 minutes and until the water is clean after installing a new filter(s). (page 9 > Operation >> Installation >>> Step 5-9)

Replacement Filter Packs				
Stage	1 st	2 nd	3 rd	4 th
Model	FPDS	FGKDS	FCDS	FTDS
F3DS	1	1	1	-
F4DS	1	1	1	1
F7DS	2	2	2	1

Troubleshooting

PROBLEM	POSSIBLE CAUSE	SUGGESTED SOLUTION
<i>The water dispenser is leaking</i>	The drain cap and silicone seal are not secure.	Ensure seal is secure in drain plug and tighten drain cap (page 6 #13).
<i>Water is not hot or cold enough</i>	The unit is unplugged.	Plug the power cord (page 6 #14) into the outlet.
	The hot water switch at the unit's panel is in the OFF position.	Activate hot water switch (page 6 #11) to the ON position.
	Indicator lights are not lit.	Connect the power cord (page 6 #14) to an electrical outlet; the cooling cycle starts automatically. Activate the hot water switch (page 6 #11) at the unit's panel.
	The circuit breaker in your home has tripped, or the fuse has blown.	Reset the breaker or replace the fuse.
	The hot water thermostat tripped (turned off).	Turn off the hot water switch (page 6 #11) for 15-30 minutes to allow the tank to cool, and then turn the switch back on. The temperature limit switch will reset automatically.
	The lower front door is not closed correctly.	Ensure the lower front door (page 6 #9) is closed adequately for proper operation.
<i>The water dispenser is not dispensing water</i>	Possible air pocket.	Push down the dispenser buttons (page 6 #1, #2, #3) to prime the unit.
	The child safety lock (hot water) is not activated.	Activate the child safety lock by sliding the red lock button to the side while pressing the hot water button (page 6 #1) at the same time.
<i>The water dispenser is noisy</i>	The water dispenser is uneven.	Make sure the dispenser is on an even surface that can support its total weight.
	The water pump makes noise as it fills the tank.	This is normal.
<i>The water dispenser is beeping</i>	Water detected by the leak-detect sensor.	Remove the leak-detect sensor (page 6 #10) from the sit, make sure it is dry, and replace it back to the sit.

Need help with troubleshooting? If you have any questions or find there are missing parts or

damage, please call **1-678-261-7611** or visit **www.ispringfilter.com**

(The model of this product is "DS4S".)

iSpring Standard Limited Warranty (End-Users Only)

In order to be eligible for this warranty, the end-user must register at www.123filter.com.

For all water filtration systems, and upon registration by the end-user, iSpring Water Systems, LLC (iSpring) warrants for a one year from the date of purchase that the product is free of defects in materials and workmanship and that it will function for the duration of the warranty according to its specifications (the "Limited Warranty"). EXCEPT FOR THIS LIMITED WARRANTY, ISPRING EXPRESSLY DISCLAIMS ANY AND ALL REPRESENTATIONS AND WARRANTIES, WHETHER EXPRESS, IMPLIED, OR STATUTORY, INCLUDING ANY WARRANTIES OF TITLE, NON-INFRINGEMENT, MERCHANTABILITY OR FITNESS FOR A PARTICULAR PURPOSE. iSpring has no liability for any defect or deterioration which results from the improper installation, service, repair or use of the product. End-user's sole and exclusive remedy for any breach of the Limited Warranty shall be repair or replacement, at iSpring's option and expense. This warranty is only provided to end-users and only applies to products purchased directly from an authorized iSpring dealer or reseller.

However, we do not have the order information from websites other than 123Filter.com (Amazon, Home Depot, etc.), so please be sure to fill in that information upon registration of your system. If you have any questions or concerns about your product, please do not hesitate to call or email us, or put it in the notes/comments upon your warranty registration. Your satisfaction is our business!

If you are happy with our products and service, please show your support by writing a product review on Amazon, even just a single line. It takes you just a minute but means a lot to us. Thank you!

Warranty Registration Form

Name _____ Order# _____

Email _____ Phone _____

Address _____

City _____ State _____ Zip Code _____

Model #/ Serial Number

Purchased at (e.g. Amazon, Home Depot)

iSpring Water Systems, LLC
2480 Industrial Park Blvd, Cumming, GA 30041
678-261-7611

Plumber's information (Optional)

To best serve our customers, we'd like to recommend good plumbers throughout the USA. If you are happy with your installer, please provide their information so that we can pass it on as a courtesy.

Thank you!

Name of the plumbing company used to install your system:

Phone #: (_____) - _____ or email : _____
of the technician.



Like our products?
Please show your support by writing a product review on the marketplace where you make your purchase. Even just a quick statement means a lot to us.

Thank you!

iSpringFilter.com

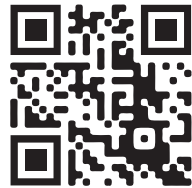

For questions, comments, or technical support, please contact us at:

✉ support@123filter.com

☎ +1 (678) 261-7611

💬 +1 (470) 560-0012

Monday-Friday 8:30 a.m. - 5:30 p.m. EST

Water's Good™
